

技術資料 Technische Documentatie **Documentation**  
Documentação técnica Documentación técnica Documentazione tecnica  
**Technische Dokumentation** Technical Documentation Техническая документация  
Documentazione tecnica Technische documentatie  
Техническая документация **Teknik Doküman** 技术资料  
**Documentazione tecnica** Dokumentacja techniczna  
Technische documentatie Documentación técnica 技術資料  
기술 자료 Technische documentatie 技術資料  
Documentation technique Teknik Doküman Dokumentacja techniczna  
Technical Documentation **Documentazione tecnica** Technical Documentation  
**Dokumentacja techniczna** 技术资料 Documentation technique  
Техническая документация Technische Dokumentation **Teknik Doküman**  
Dokumentacja techniczna Technische documentatie  
Documentation technique 기술 자료 Dokumentacja techniczna

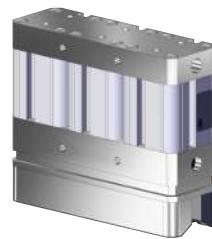

Magnetic Gripper SGM-HP 40x121 / SGM-HT-HP 40x121

# Assembly Instructions

**Note**

The Assembly instructions were originally written in German. Store in a safe place for future reference. Subject to technical changes without notice. No responsibility is taken for printing or other types of errors.

**Published by**

© J. Schmalz GmbH, 11/20

This document is protected by copyright. J. Schmalz GmbH retains the rights established thereby. Reproduction of the contents, in full or in part, is only permitted within the limits of the legal provisions of copyright law. Any modifications to or abridgments of the document are prohibited without explicit written agreement from J. Schmalz GmbH.

**Contact**

J. Schmalz GmbH  
Johannes-Schmalz-Str. 1  
72293 Glatten, Germany  
T: +49 7443 2403-0  
schmalz@schmalz.de  
www.schmalz.com

Contact information for Schmalz companies and trade partners worldwide can be found at:  
[www.schmalz.com/salesnetwork](http://www.schmalz.com/salesnetwork)

# Contents

<b>1</b>	<b>Important Information</b>	<b>5</b>
1.1	The technical documentation is part of the product	5
1.2	Note on Using this Document	5
1.3	Warnings in This Document	5
1.4	Symbol	5
1.5	Type Plate	5
1.6	Other Applicable Documents	6
<b>2</b>	<b>Fundamental Safety Instructions</b>	<b>7</b>
2.1	Intended Use	7
2.2	Non-Intended Use	7
2.3	Danger Zone	7
2.4	Environmental and Operating Conditions	8
2.5	Personnel Qualifications	8
2.6	Technical Condition	8
2.7	Responsibility of the Integrator	8
2.8	Country-Specific Regulations for the Operating Company	9
<b>3</b>	<b>Product Description</b>	<b>10</b>
3.1	Description of the Magnetic Gripper	10
3.2	Variants and Type Key	10
<b>4</b>	<b>Technical Data</b>	<b>11</b>
4.1	General Parameters	11
4.2	Dimensions	12
<b>5</b>	<b>Transport and Storage</b>	<b>13</b>
5.1	Checking the Delivery	13
5.2	Reusing the Packaging	13
<b>6</b>	<b>Installation</b>	<b>14</b>
6.1	Installation Instructions	14
6.2	Mechanical Attachment	14
6.3	Pneumatic connection	15
<b>7</b>	<b>Start of Operations</b>	<b>16</b>
7.1	Personnel Qualification	16
7.2	Before Initial Start of Operations	16
<b>8</b>	<b>Operation</b>	<b>17</b>
8.1	Preparations	17
<b>9</b>	<b>Troubleshooting</b>	<b>18</b>
9.1	Safety	18
9.2	Faults, Causes, Solutions	18
<b>10</b>	<b>Maintenance</b>	<b>20</b>
10.1	Safety	20
10.2	Maintenance Schedule	20

10.3	Cleaning the Magnetic Gripper.....	21
10.4	Accessories, Spare Parts and Wearing Parts.....	21
<b>11</b>	<b>Disposing of the Product.....</b>	<b>23</b>

# 1 Important Information

## 1.1 The technical documentation is part of the product

1. For problem-free and safe operation, follow the instructions in the documents.
  2. Keep the technical documentation in close proximity to the product. The documentation must be accessible to personnel at all times.
  3. Pass on the technical documentation to subsequent users.
- ⇒ Failure to follow the instructions in these Assembly instructions may result in injuries!
- ⇒ Schmalz is not liable for damage or malfunctions that result from failure to heed these instructions.

If you still have questions after reading the technical documentation, contact Schmalz Service at:  
[www.schmalz.com/services](http://www.schmalz.com/services)

## 1.2 Note on Using this Document

J. Schmalz GmbH is generally referred to as Schmalz in these Assembly instructions.

These Assembly instructions contain important notes and information about the different operating phases of the product:

- Transport, storage, start of operations and decommissioning
- Safe operation, required maintenance, rectification of any faults

The Assembly instructions describe the product at the time of delivery by Schmalz.

## 1.3 Warnings in This Document

Warnings warn against hazards that may occur when handling the product. The signal word indicates the level of danger.

Signal word	Meaning
WARNING	Indicates a medium-risk hazard that could result in death or serious injury if not avoided.
CAUTION	Indicates a low-risk hazard that could result in minor or moderate injury if not avoided.
NOTE	Indicates a danger that leads to property damage.

## 1.4 Symbol



This symbol indicates useful and important information.

- ✓ This symbol represents a prerequisite that must be met prior to an operational step.
- ▶ This symbol represents an action to be performed.
- ⇒ This symbol represents the result of an action.

Actions that consist of more than one step are numbered:

1. First action to be performed.
2. Second action to be performed.

## 1.5 Type Plate

The type plate is permanently attached to the product and must always be clearly legible.

The type plate contains the following data:

- Company logo/address
- Part sales designation/type
- Manufacturing date
- Serial number
- Permitted pressure range
- QR code
- ▶ Please specify all the information above when ordering replacement parts, making warranty claims or for any other inquiries.

## **1.6 Other Applicable Documents**

The following operating instructions must also be observed when setting up the magnetic gripper:

- The operating instructions 30.30.01.01624 for the proximity switch.

## 2 Fundamental Safety Instructions

### 2.1 Intended Use



#### **⚠ WARNING**

**The product contains a permanent magnet that generates a continuous magnetic field.**

Danger for persons with pacemakers. Devices and data carriers can be damaged.

- ▶ Keep persons with pacemakers away from the product.
- ▶ Keep sensitive electrical devices and data carriers away from the product.

The magnetic gripper is used for handling ferromagnetic workpieces, such as perforated plates, complex laser-cut workpieces, plates with drill holes and apertures.

The operator is required to document the static strength and holding force and to adhere to safety factors.

For system designs, a safety factor of  $S=3$  should be applied.

The loads to be lifted must be rigid enough to ensure they are not destroyed during lifting.

The magnetic gripper is built in accordance with the latest standards of technology and is shipped in safe condition. However, hazards can arise during use. Observe the warnings in these operating instructions.

The maximum lift capacity must not be exceeded ( $>$  See *ch. Technical Data*).

Do not operate the device in environments where there is a risk of explosion.

Do not operate the product in aggressive environments (e.g. ambient air containing solvent fumes).

### 2.2 Non-Intended Use

Schmalz accepts no liability for damage caused by the use of the gripper for purposes other than those described under Intended Use. Use of the gripper for loads that are not specified in the order confirmation or that have different physical properties than those specified in the order confirmation shall be considered non-intended use. In particular, the following are considered non-intended use:

- Use as a climbing aid
- Lifting people or animals
- Storing loads when active
- Supporting the lifting process by applying external forces
- Freeing building components or immovable equipment

### 2.3 Danger Zone

Persons in the danger zone of the gripper may suffer life-threatening injuries.

The system integrator must carry out a risk assessment of the entire system and define the danger zone precisely. In doing so, country-specific provisions and regulations must be observed.

Automatic operation on the industrial robot or gantry

- During automatic operation of the handling system, no persons or animals may be present in the danger zone.
- In other operating modes, ensure that no unauthorized persons or animals are present in the danger zone.
- Ensure that collisions with the surrounding environment and objects do not occur to prevent the load from breaking off.

During automatic operation of the handling system, the danger zone must be secured to prevent access by persons (protective barrier or sensor system).

The danger zone of the gripper includes the following areas:

- The area directly below the gripper and load.
- The area immediately surrounding the gripper and load.
- The working area of the automatic handling system.

## 2.4 Environmental and Operating Conditions

The gripping system must **not** be operated under the following conditions:

- In potentially explosive atmospheres
- Use in an environment with acidic or alkaline media

The gripping system must be operated only under the following conditions:

- The gripping system must be sufficiently dimensioned for the loads to be lifted.
  - ▶ If in doubt, consult Schmalz before the start of operations.

## 2.5 Personnel Qualifications

Unqualified personnel cannot recognize dangers and are therefore exposed to higher risks!

The operating company must ensure the following points:

- The personnel must be commissioned for the activities described in these instructions.
- The staff must be at least 18 years of age and physically and mentally capable.
- The product must be operated only by persons who have undergone appropriate training.
- Personnel must receive regular safety briefings (frequency as per country-specific regulations).
- Installation, maintenance, and repairs must be carried out only by specialists from J. Schmalz GmbH or by persons who can prove that they have undergone appropriate training at Schmalz.

The following target groups are addressed in these instructions:

- Mechanical and electrical specialists who are responsible for installing, troubleshooting and maintaining the product.

The operator of the system must comply with country-specific regulations regarding the age, ability and training of the personnel.

Valid for Germany:

A qualified employee is defined as an employee who has received technical training and has the knowledge and experience – including knowledge of applicable regulations – necessary to enable him or her to recognize possible dangers and implement the appropriate safety measures while performing tasks. Qualified personnel must observe the pertinent industry-specific rules and regulations.

## 2.6 Technical Condition

If the product is operated while in a defective state, safety and function will be impaired.

- Only operate the gripper when in perfect working order as originally delivered.
- Follow the maintenance schedule.
- Use only original spare parts from Schmalz.
- If the operating behavior changes, check the gripper for faults. Rectify faults immediately!
- Do not independently modify or alter the gripper.
- Safety features must not be disabled under any circumstances.

Schmalz assumes no liability for consequences of modifications over which it has no control.

## 2.7 Responsibility of the Integrator

The integrator is obligated to perform a risk assessment for the environmental conditions at the installation location.



The integrator is also responsible for third parties in the working area of the gripper. The operating company must ensure that they have the appropriate qualifications and skills.

- Ensure that regular breaks are taken.
- Ensure that the gripper cannot be started up by unauthorized persons.
- During maintenance or repair work, ensure that the gripper cannot be operated.
- Clearly define the responsibilities for the various activities performed with the gripper.
- Ensure that these responsibilities are observed.
- When handling unfamiliar loads, carry out tests where necessary to ensure safe operation:
  - The load is sufficiently rigid that it cannot be damaged during handling.

## **2.8 Country-Specific Regulations for the Operating Company**

1. Observe the country-specific regulations regarding accident prevention, safety testing and environmental protection.
2. The gripper is to be used in combination with an automated handling system (gantry/robot). Ensure that the appropriate country-specific regulations and safety regulations are adhered to.

### 3 Product Description

#### 3.1 Description of the Magnetic Gripper

Magnetic grippers lift ferromagnetic workpieces using magnetic force. They are used for handling sheet metal, perforated plates, complex laser-cut workpieces, sheets with drill holes as well as apertures, corrugated sheets, and pipes.

By applying compressed air, the permanent magnets are moved towards the gripping surface (gripping the workpiece) or away from the gripping surface (depositing the workpiece).

The bistable mode of operation allows safe gripping even during a power failure.

The gripper is available in two different versions:

- Magnetic gripper SGM-HP 40x121 with very high holding forces  
For demanding applications with an operating temperature of up to 70° C
- Magnetic gripper SGM-HT-HP 40x121 with very high holding forces  
For demanding high-temperature applications with an operating temperature of up to 150° C and workpiece temperature of up to 350° C

The (external) compressed air generation is not included in the scope of delivery. If you have any questions about the design, please contact the Schmalz service team at:

[www.schmalz.com/services](http://www.schmalz.com/services)

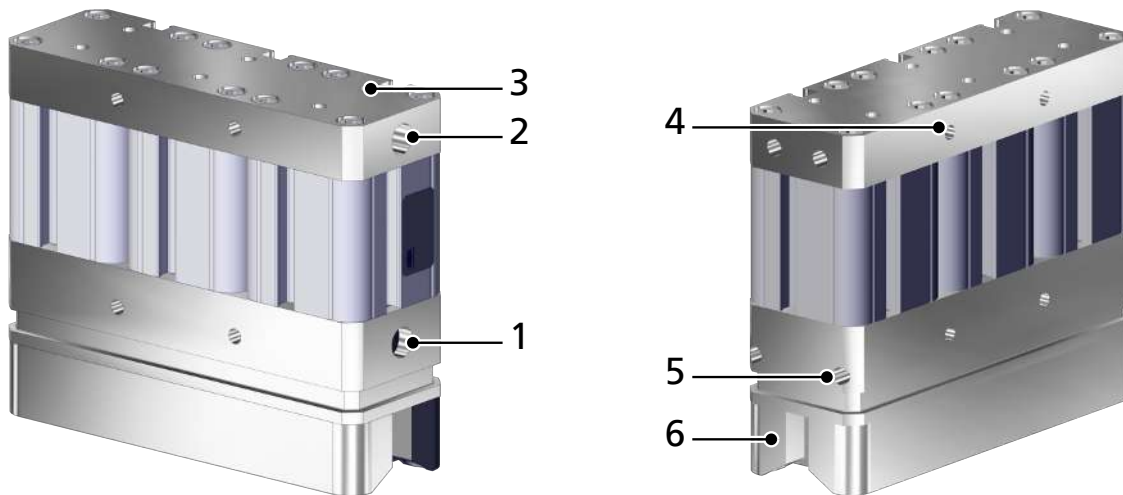

1	1/8" compressed air connection (depositing workpiece)	2	1/8" compressed air connection (gripping workpiece)
3	M5 mounting thread (6x) for universal connection	4	M5 mounting thread (4x) for lateral holder systems (> See ch. Accessories)
5	M6 mounting thread (4x) for front holder systems (> See ch. Accessories)	6	Support rail (2x)

#### 3.2 Variants and Type Key

The magnetic gripper is available in two different versions. The version is indicated in the item designation. The item designation is composed as follows:

Part number	Type name	High-temperature	High power	Gripping surface
10.01.17.00566	SGM-HP 40x121	---	HP	121 x 40 mm
10.01.17.00544	SGM-HT-HP 40x121	HT	HP	121 x 40 mm

## 4 Technical Data



### 4.1 General Parameters

Parameter	Gripper type		Unit
	SGM-HP 40x121	SGM-HT-HP 40x121	
Operating medium	Air or neutral gas, 40 µm filtered, with or without oil, class 7-4-4 compressed air quality acc. to ISO 8573-1		
Holding force <sup>1</sup> ≥ 0.5 mm, sheet metal	65	75	N
Holding force <sup>1</sup> ≥ 0.7 mm, sheet metal	120	140	N
Holding force <sup>1</sup> ≥ 1 mm, sheet metal	270	230	N
Holding force <sup>1</sup> ≥ 2 mm, sheet metal	580	600	N
Max. holding force <sup>1</sup>	1070	1170	N
Lateral force, dry <sup>2</sup>	210	190	N
Lateral force, oily <sup>2</sup>	160	175	N
Residual holding force	≤ 2.5		N
Opt. operating pressure	2.5 ... 6.0		bar
Ambient temperature	5 ... 70	max. 150	°C
Contact temperature	max. 70	max. 350 <sup>3</sup>	°C
Mode of operation	bistable		
Mounting position	any		
Weight	1500		g

<sup>1</sup> All holding forces are static and unsecured when gripper active surfaces are fully covered on steel plate S235 at +20 °C.

<sup>2</sup> 2 mm steel plate

<sup>3</sup> Can be used for workpiece temperatures up to 350° C (depending on process conditions). The influence of temperature can reduce holding forces by up to 30%.

-  As the operating temperature increases, the holding force of the grippers decreases. We recommend performing tests before continuous operation.
-  The specified values apply to clean, smooth surfaces for low-carbon steel sheets. Dirty, rough, and highly alloyed steel sheets reduce the holding force.
-  For maximum holding forces, the component to be handled must completely cover the gripping surface.  
Due to the design of the gripper, it is not possible to centrally grip parts that are smaller than the gripping surface.

## 4.2 Dimensions

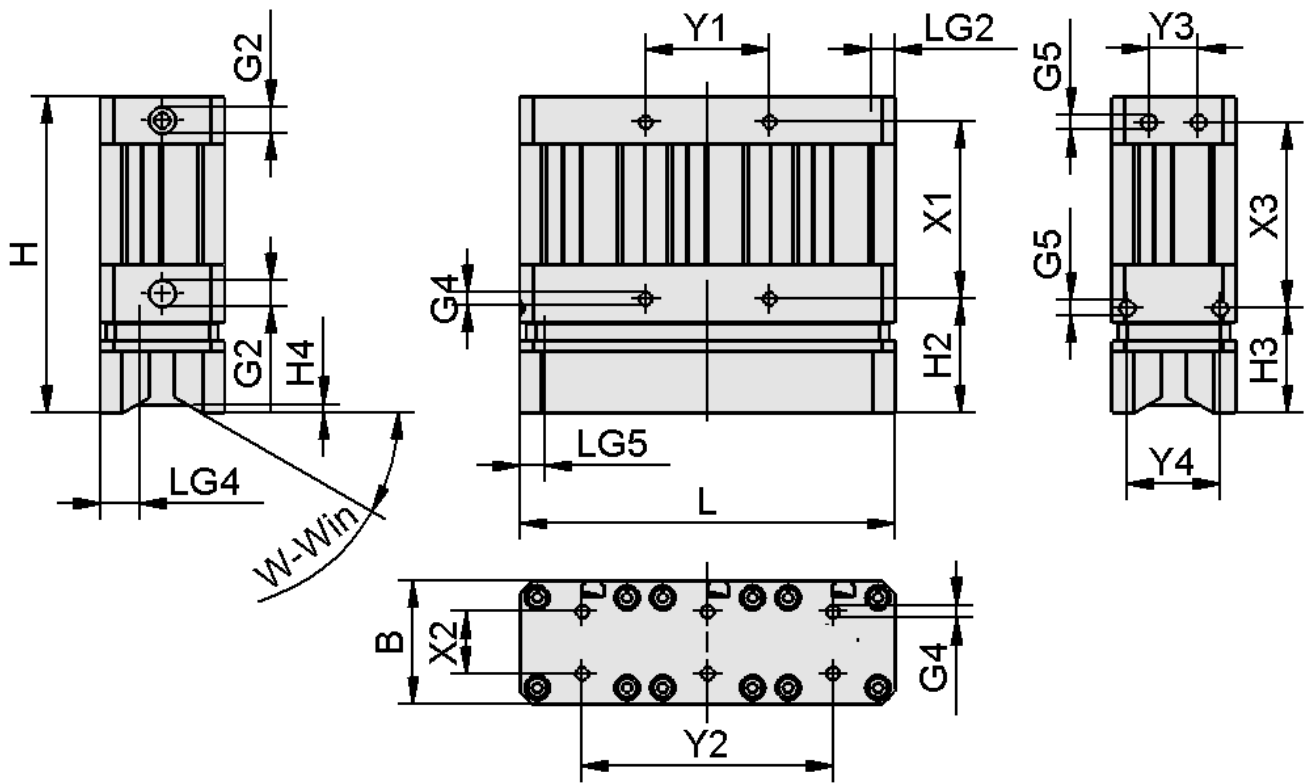

L	B	H	H2	H3	H4	X1	X2	X3	Y1
121	40	102	36.7	33.6	2.6	57	20	60	40
Y2	Y3	Y4	G2	LG2	G4	LG4	G5	LG5	W
81	16	30	1/8" internal thread	7	M5 internal thread	7	M6 internal thread	6.5	30°

All specifications except angles given in mm.

## 5 Transport and Storage

### 5.1 Checking the Delivery

The scope of delivery can be found in the order confirmation. The weights and dimensions are listed in the delivery notes.

1. Compare the entire delivery with the supplied delivery notes to make sure nothing is missing.
2. Damage caused by defective packaging or occurring in transit must be reported immediately to the carrier and J. Schmalz GmbH.

### 5.2 Reusing the Packaging

The product is delivered in cardboard packaging. The packaging should be reused to safely transport the product at a later stage.



Keep the packaging for future transport or storage.

## 6 Installation

### 6.1 Installation Instructions



#### ⚠ WARNING

The product contains a permanent magnet that generates a continuous magnetic field.

Danger for persons with pacemakers. Devices and data carriers can be damaged.

- ▶ Keep persons with pacemakers away from the product.
- ▶ Keep sensitive electrical devices and data carriers away from the product.



#### ⚠ CAUTION

##### Improper installation or maintenance

Personal injury or damage to property

- ▶ Prior to installation and before maintenance work, the product must be disconnected from the power supply, depressurized (vented to the atmosphere) and secured against unauthorized restart.

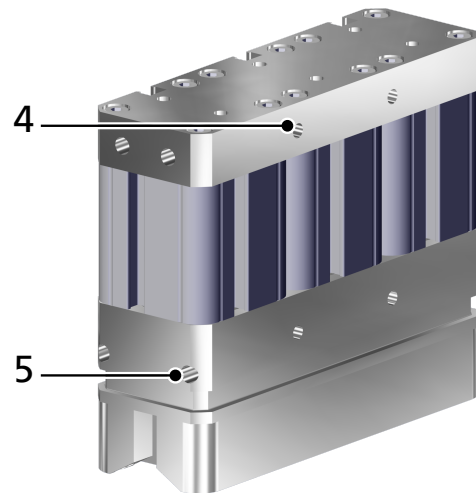
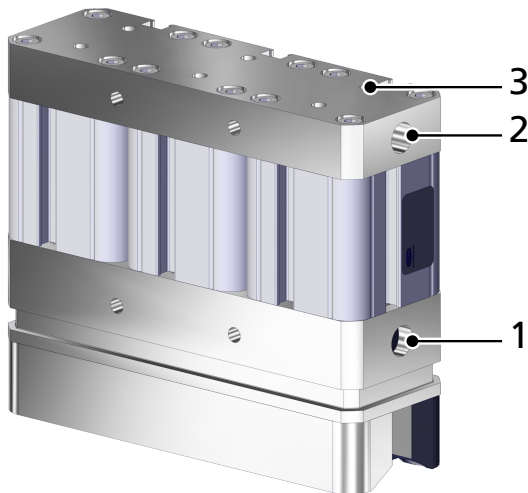

- |   |                                                                     |
|---|---------------------------------------------------------------------|
| 1 | 1/8" compressed air connection (depositing workpiece)               |
| 3 | M5 mounting thread (6x) for universal connection                    |
| 5 | M6 mounting thread (4x) for holder systems (> See ch. Accessories ) |

- |   |                                                                     |
|---|---------------------------------------------------------------------|
| 2 | 1/8" compressed air connection (gripping workpiece)                 |
| 4 | M5 mounting thread (4x) for holder systems (> See ch. Accessories ) |

### 6.2 Mechanical Attachment

The gripper is adapted to the handling system either directly or by using interchangeable holder systems. The holder systems can be chosen from the range of accessories. (> See ch. Accessories)

The gripper may be installed in any position.

### **6.3 Pneumatic connection**

1. Shorten the hoses and pipelines as much as possible.
2. Keep hose lines free of bends and crimps.
3. Lay hose lines in such a way that they do not rub.

## 7 Start of Operations

### 7.1 Personnel Qualification

Unqualified personnel cannot recognize dangers and are therefore exposed to higher risks!

1. Only instruct qualified personnel to perform the tasks described in these operating instructions.
2. The product may only be operated by persons who have undergone appropriate training.
3. Electrical work and installations may only be carried out by qualified electrical specialists.
4. Assembly and maintenance work must only be carried out by qualified personnel.

### 7.2 Before Initial Start of Operations

Before the initial start of operations following the installation, repair, servicing or maintenance work, you must check the following:

- All mechanical connectors are properly attached and secured.
- All screws and nuts are tightened to specified torques.
- All components are installed.
- The safety distances have been maintained.
- The supply hoses are properly routed.
- The EMERGENCY STOP switch for the overall system is working.
- The type plate and "Warning of Magnetic Field" sign are present and easy to read.



#### **⚠ CAUTION**

**Noise pollution due to incorrect installation of the pressure and vacuum connections**

Hearing damage

- ▶ Correct installation.
- ▶ Wear ear protectors.



#### **⚠ CAUTION**

**Risk of crushing if workpiece is abruptly attached**

- ▶ Do not place any body parts between the gripping surface and workpiece.



## 8 Operation

### 8.1 Preparations

- ▶ The product must be operated only by persons who have undergone appropriate training.



#### **⚠ WARNING**

**The product contains a permanent magnet that generates a continuous magnetic field.**

Danger for persons with pacemakers. Devices and data carriers can be damaged.

- ▶ Keep persons with pacemakers away from the product.
- ▶ Keep sensitive electrical devices and data carriers away from the product.

To avoid injury, always use appropriate protective equipment that is suitable for the situation. The protective equipment must meet the following standards:

- Protective work shoes in safety class S1 or higher
- Ear protection class L or higher
- Sturdy work gloves in safety category 2231 or higher
- Eye protection class F

Before each activation of the gripping system, the following measures must be taken:

1. Check the device for visible damage. Correct any faults or report them to the supervising personnel.
2. Ensure that only authorized persons are present in the working area of the machine or system in order to prevent any hazard from switching on the machine.
3. Ensure that the danger zone of the machine or system is free of persons during automatic operation.

## 9 Troubleshooting

### 9.1 Safety

Maintenance work may only be carried out by qualified personnel.



#### **⚠ WARNING**

##### **Risk of injury due to incorrect maintenance or troubleshooting**

- ▶ Check the proper functioning of the product, especially the safety features, after every maintenance or troubleshooting operation.



#### **⚠ CAUTION**

##### **Improper installation or maintenance**

Personal injury or damage to property

- ▶ Prior to installation and before maintenance work, the product must be disconnected from the power supply, depressurized (vented to the atmosphere) and secured against unauthorized restart.

### 9.2 Faults, Causes, Solutions

Fault	Possible cause	Solution
Workpiece is not gripped	Magnets are not in the corresponding end position	Check compressed air supply Check hose connections and plug-in screw unions
	Pressure too low	
Magnetic gripper leaks when compressed air is applied	Sealing elements damaged; use at too high contact or ambient temperature	Maintain defined temperature ranges for the HP and HT-HP variants.
Workpiece is only gripped with reduced holding force	The workpiece to be handled does not completely cover the gripping surface.	For maximum holding forces, the workpiece to be handled must completely cover the gripping surface.
	Support rail damaged	Replace damaged support rails.
	Ferromagnetic pollutants on the gripping surface (e.g. iron shavings)	Clean the gripping surface.
	Support rails have no or insufficient contact to the pole shoes	When mounting the support rails, ensure that the contact to the pole shoes is flat.
	The workpiece to be gripped has a dirty and/or rough surface or is highly alloyed.	If possible, only handle low-carbon workpieces (steel sheets) with a clean and smooth surface.
	The operating or ambient temperature is too high.	Maintain defined temperature ranges for the HP and HT-HP variants; if necessary, perform tests before continuous operation.
<b>When using sensors (for 10.01.17.00566 only)</b>		
Sensor (for monitoring the piston position) cannot be taught	Sensor defective	Replace the sensor.

Fault	Possible cause	Solution
Sensor cannot be taught or can only be taught with errors	Teaching is performed using a magnetizable tool (e.g. ballpoint pen refill, hexagon wrench, etc.).	Use the teach-in tool supplied with the sensor or a comparable plastic pen.
Sensor signal is lost or faulty	Sensor not fully inserted into the corresponding sensor slot; sensor fastening screw is loose	Push sensor in as far as possible and tighten fastening screw with specified torque.
	Magnetic interference fields	Avoid magnetic interference fields and maintain minimum distances.
	Ferromagnetic pollutants in the area of the sensor slot (e.g. iron shavings)	Check the sensor slot(s) at regular intervals and clean them if necessary.

# 10 Maintenance

## 10.1 Safety

Maintenance work may only be carried out by qualified personnel.



### ⚠️ WARNING

#### Risk of injury due to incorrect maintenance or troubleshooting

- ▶ Check the proper functioning of the product, especially the safety features, after every maintenance or troubleshooting operation.



### ⚠️ CAUTION

#### Improper installation or maintenance

Personal injury or damage to property

- ▶ Prior to installation and before maintenance work, the product must be disconnected from the power supply, depressurized (vented to the atmosphere) and secured against unauthorized restart.

## 10.2 Maintenance Schedule



Schmalz stipulates the following checks and check intervals. The operator must comply with the legal regulations and safety regulations applicable at the location of use. These intervals apply to single-shift operation. For heavier use, such as multi-shift operation, the intervals must be shortened accordingly.

Maintenance task	Daily	Weekly	Monthly	Every six months	Yearly
Check the level of wear on the support rails		X			

### Replacing the support rails

The wearing part set contains the following single components:

- Support rails (2x)
- Locking washers (8x)
- Machine screws (8x)

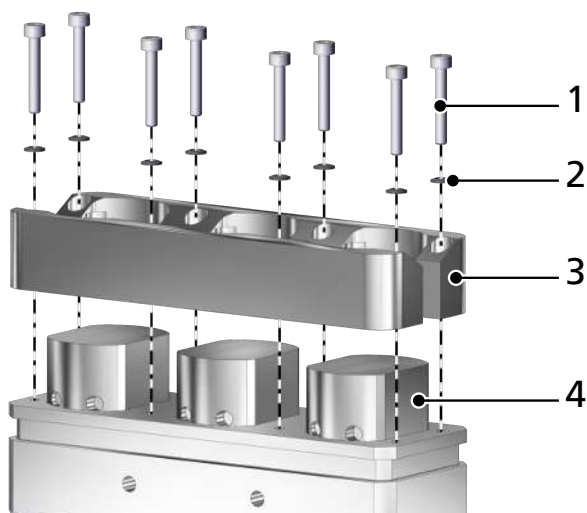

1. Release the screws (1).
2. Dispose of screws, locking washers, and support rails (1-3).
3. Clean the installation environment (housing base with integrated pole shoes) if necessary.
4. Put on new support rails.
5. Insert new screws and locking washers from the spare parts set into the counterbores.
6. Tighten the screws to 1.4 Nm.

**i** During tightening, ensure that the contact rails are completely in contact with the pole shoes (4).  
A possible air gap reduces the holding forces.

### 10.3 Cleaning the Magnetic Gripper

1. For cleaning, do not use aggressive cleaning agents such as industrial alcohol, white spirit or thinners. Only use cleaning agents with pH 7–12.
2. Remove dirt on the exterior of the device with a soft cloth and soap suds.
3. Ensure that no moisture gets into the sensors.

### 10.4 Accessories, Spare Parts and Wearing Parts

#### Accessories

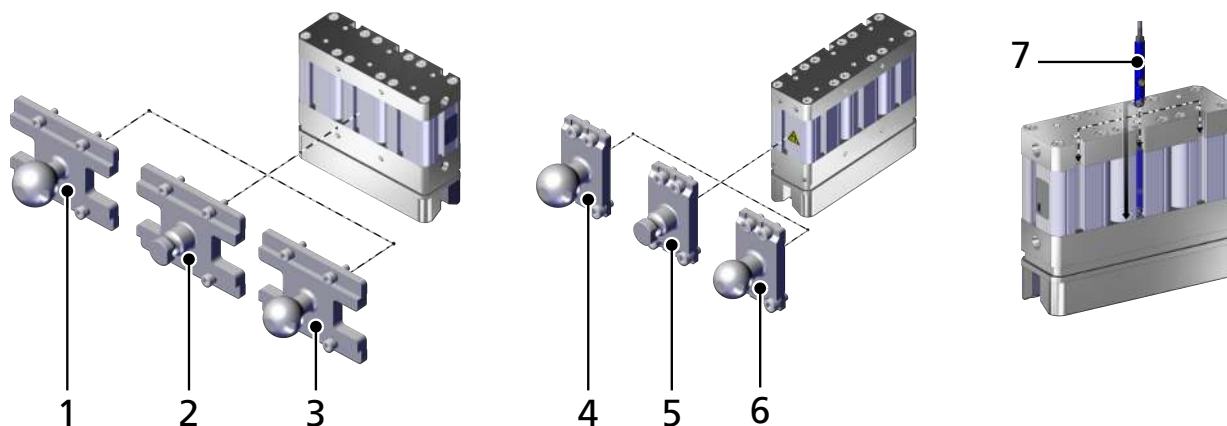

Item	Name	Part no.	Note
1	Holder system HTS-A5 SGM-HP 40x121	10.01.17.00559	Ball diameter 32 mm
2	Holder system HTS-A2 SGM-HP 40x121	10.01.17.00570	
3	Holder system HTS-A3 SGM-HP 40x121	10.01.17.00546	Ball diameter 28.5 mm
4	Holder system HTS-A5 EW SGM-HP 40x121	10.01.17.00589	Ball diameter 32 mm
5	Holder system HTS-A2 EW SGM-HP 40x121	10.01.17.00591	
6	Holder system HTS-A3 EW SGM-HP 40x121	10.01.17.00590	Ball diameter 28.5 mm
7	PNP proximity switch <sup>1</sup> PNP sensor	10.01.17.00199	SGM-HP-40x121 only
	NPN proximity switch <sup>1</sup> NPN sensor	10.01.17.00215	
Not shown	Sensor screw (left-hand thread) ZUB SGM-S NAEH-SCHA SCREW	10.01.17.00509	SGM-HT-HP-40x121 only
	Plastic pin for sensor ZUB SGM-S NAEH-SCHA PIN	10.01.17.00510	
	Straight plug-in screw union STV-GE G1/8-AG 6	10.08.02.00204	
	Plug-in screw union bracket STV-W G1/8-AG 6	10.08.02.00158	
	Vacuum hose VSL 6-4 PU	10.07.09.00002	
	Straight plug-in screw union STV-GE G1/8-AG 6 HT	10.08.02.00389	
	Plug-in screw union bracket STV-W G1/8-AG 6 HT	10.08.02.00391	
	Vacuum hose VSL 6-4 PTFE	10.07.09.00157	

<sup>1</sup> There are three sensor slots available to accommodate the sensor(s).  
When using only one sensor, the middle sensor slot is recommended. If all three piston positions are to be queried, proximity switches must be provided in all three sensor slots.

### Spare and Wearing Parts

Designation	Part no.	Note
Spare parts set ERS SGM-40x121 2RAILS	10.01.17.00572	Wearing part

## 11 Disposing of the Product

Recover the disassembled parts for recycling or reuse (provided no agreement on return or disposal has been made).

1. Dispose of the product properly after replacement or decommissioning.
2. Observe the country-specific guidelines and legal obligations for waste prevention and disposal.

## At your side worldwide

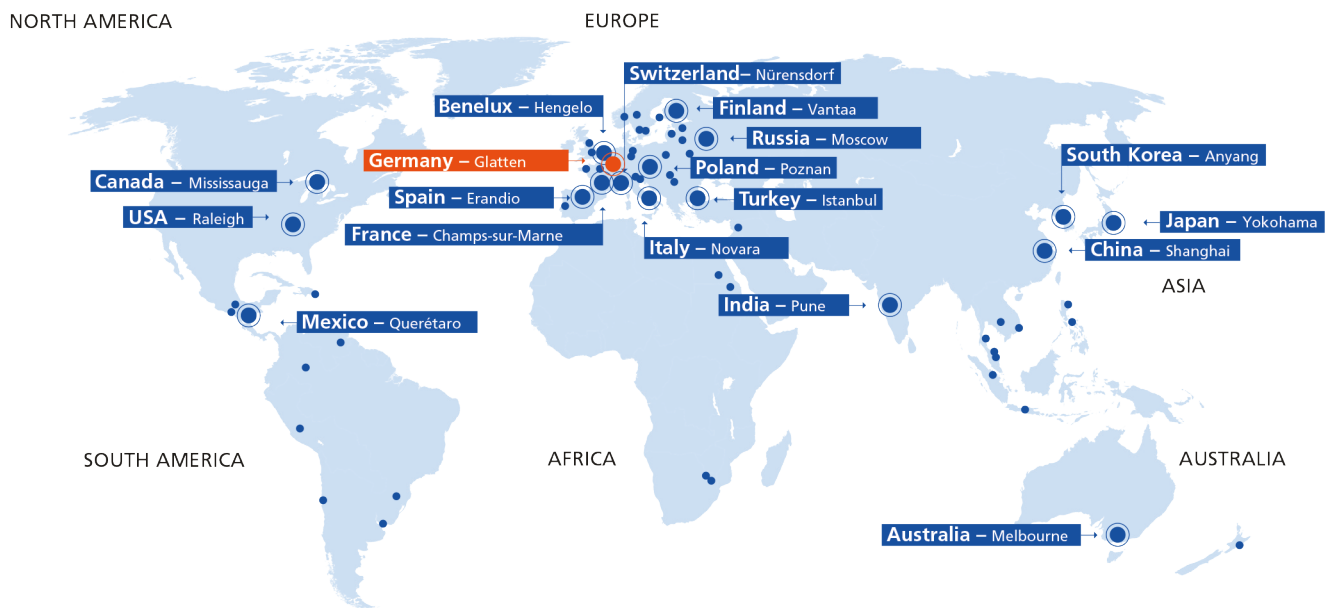

**Headquarters**

Schmalz Germany – Glatten

**Sales Partners**

You can find the Schmalz sales partner in your country at:  
[WWW.SCHMALZ.COM/SALESNETWORK](http://WWW.SCHMALZ.COM/SALESNETWORK)

**Subsidiaries**

- Schmalz Australia – Melbourne
- Schmalz Benelux – Hengelo (NL)
- Schmalz Canada – Mississauga
- Schmalz China – Shanghai
- Schmalz Finland – Vantaa
- Schmalz France – Champs-sur-Marne
- Schmalz India – Pune
- Schmalz Italy – Novara
- Schmalz Japan – Yokohama

- Schmalz Mexico – Querétaro
- Schmalz Poland – Suchy Las (Poznan)
- Schmalz Russia – Moscow
- Schmalz South Korea – Anyang
- Schmalz Spain – Erandio (Vizcaya)
- Schmalz Switzerland – Nürens Dorf
- Schmalz Turkey – Istanbul
- Schmalz USA – Raleigh (NC)

### Vacuum Automation

[WWW.SCHMALZ.COM/AUTOMATION](http://WWW.SCHMALZ.COM/AUTOMATION)

### Handling Systems

[WWW.SCHMALZ.COM/HANDLINGSYSTEMS](http://WWW.SCHMALZ.COM/HANDLINGSYSTEMS)

J. Schmalz GmbH  
 Johannes-Schmalz-Str. 1  
 72293 Glatten, Germany  
 T: +49 7443 2403-0  
 schmalz@schmalz.de  
 WWW.SCHMALZ.COM