

## Vacuum Reservoir VOL

# Operating Instructions

### Note

The Operating instructions were originally written in German. Store in a safe place for future reference. Subject to technical changes without notice. No responsibility is taken for printing or other types of errors.

### Published by

© J. Schmalz GmbH, 03/20

This document is protected by copyright. J. Schmalz GmbH retains the rights established thereby. Reproduction of the contents, in full or in part, is only permitted within the limits of the legal provisions of copyright law. Any modifications to or abridgments of the document are prohibited without explicit written agreement from J. Schmalz GmbH.

J. Schmalz GmbH · Johannes-Schmalz-Str. 1 · 72293 Glatten, Germany · T: +49 7443 2403-0  
schmalz@schmalz.de

# Contents

- 1 Important Information ..... 3**
  - 1.1 Note on Using this Document ..... 3
  - 1.2 The technical documentation is part of the product ..... 3
  - 1.3 Warnings in this document..... 3
  - 1.4 Symbol..... 3
  - 1.5 Type Plate ..... 4
  
- 2 Fundamental Safety Instructions ..... 4**
  - 2.1 Intended Use..... 4
  - 2.2 Safety Instructions ..... 4
  - 2.3 Modifications to the Product..... 4
  - 2.4 Personnel Qualifications ..... 5
  - 2.5 Danger Zone ..... 5
  
- 3 Design of vacuum reservoir VOL ..... 5**
  
- 4 Technical Data ..... 6**
  - 4.1 General Parameters..... 6
  - 4.2 Dimensions..... 6
  
- 5 Checking the Delivery ..... 6**
  
- 6 Installation..... 7**
  - 6.1 Installation Instructions..... 7
  - 6.2 Transport..... 7
  - 6.3 Installation Site..... 7
  - 6.4 Installation Procedure ..... 7
  - 6.5 Connecting the Vacuum Pump and Gripping System ..... 7
  - 6.6 Safety Feature..... 8
  
- 7 Starting Up the Device ..... 8**
  
- 8 Maintenance and Cleaning ..... 8**
  - 8.1 Filter ..... 8
  
- 9 Troubleshooting..... 9**
  
- 10 Warranty..... 9**
  
- 11 Spare and Wearing Parts..... 9**
  
- 12 Disposing of the Product..... 9**
  
- 13 EC Declaration of Conformity ..... 9**

# 1 Important Information

## 1.1 Note on Using this Document

J. Schmalz GmbH is generally referred to as Schmalz in these Operating instructions.

These Operating instructions contain important notes and information about the different operating phases of the product:

- Transport, storage, start of operations and decommissioning
- Safe operation, required maintenance, rectification of any faults

The Operating instructions describe the product at the time of delivery by Schmalz.

## 1.2 The technical documentation is part of the product

1. For problem-free and safe operation, follow the instructions in the documents.
2. Keep the technical documentation in close proximity to the product. The documentation must be accessible to personnel at all times.
3. Pass on the technical documentation to subsequent users.
  - ⇒ Failure to follow the instructions in these Operating instructions may result in life-threatening injuries!
  - ⇒ Schmalz is not liable for damage or malfunctions that result from failure to heed these instructions.

If you still have questions after reading the technical documentation, contact Schmalz Service at:

[www.schmalz.com/services](http://www.schmalz.com/services)

## 1.3 Warnings in this document

Warnings warn against hazards that may occur when handling the product. There are four levels of danger that you can recognize by the signal word.

Signal word	Meaning
DANGER	Indicates a high-risk hazard which, if not avoided, will result in death or serious injury.
WARNING	Indicates a medium-risk hazard which, if not avoided, could result in death or serious injury.
CAUTION	Indicates a low-risk hazard which, if not avoided, could result in minor or moderate injury.
NOTE	Indicates a danger that leads to property damage.

## 1.4 Symbol



This symbol indicates useful and important information.

- ✓ This symbol represents a prerequisite that must be met prior to an operational step.
- ▶ This symbol represents an action to be performed.
- ⇒ This symbol represents the result of an action.

Actions that consist of more than one step are numbered:

1. First action to be performed.
2. Second action to be performed.

## 1.5 Type Plate

The type plate contains important information regarding the vacuum reservoir.

The type plate is attached to the exterior of the device. It is permanently attached to the vacuum reservoir and must always be clearly legible.

It includes the following information:

- Part sales designation/type
- Article/part number
- Manufacturing date
- CE label

Please specify all the information above when ordering replacement parts, making warranty claims or for any other inquiries.

## 2 Fundamental Safety Instructions

### 2.1 Intended Use

The vacuum reservoir is built in accordance with the latest standards of technology and is delivered in a safe operating condition.

The vacuum reservoir VOL from Schmalz is used to maintain a specific vacuum volume.

Neutral gases in accordance with EN 983 are approved as evacuation media. Neutral gases include air, nitrogen and inert gases (e.g. argon, xenon and neon).

Before conveying a gas, check whether the gas can be conveyed safely in the specific application.

Corresponding security measures on systems and devices that are connected to the vacuum reservoir must be implemented in order to avoid danger to persons, animals or property caused by a drop in vacuum.

The product is intended for industrial use.

Intended use includes observing the technical data and the installation and operating instructions in this manual.

### 2.2 Safety Instructions



#### **⚠ WARNING**

##### **A powerful vacuum flow creates a strong suction effect**

Risk of injury to eyes or other body parts

- ▶ Wear eye protection.
- ▶ Do not look or reach into any vacuum vent.
- ▶ When the vacuum generator is switched on, maintain a safe distance from the vacuum vent.



#### **⚠ WARNING**

##### **Extraction of hazardous media, liquids or bulk material**

Personal injury or damage to property!

- ▶ Do not extract harmful media such as dust, oil mists, vapors, aerosols etc.
- ▶ Do not extract aggressive gases or media such as acids, acid fumes, bases, biocides, disinfectants or detergents.
- ▶ Do not extract liquids or bulk materials, e.g. granulates.

### 2.3 Modifications to the Product

Schmalz assumes no liability for consequences of modifications over which it has no control:

1. The product must be operated only in its original condition as delivered.
2. Use only original spare parts from Schmalz.
3. The product must be operated only in perfect condition.

## 2.4 Personnel Qualifications

Unqualified personnel cannot recognize dangers and are therefore exposed to higher risks!

1. Task only qualified personnel to perform the tasks described in this Operating instructions.
2. The product must be operated only by persons who have undergone appropriate training.

This Operating instructions is intended for fitters who are trained in handling the product and who can operate and install it.

## 2.5 Danger Zone

Persons in the danger zone of the overall system may suffer severe injuries.

The danger zone is the area inside or in the vicinity of working equipment that poses a hazard or potential hazard to the health of persons located within this area.

The vacuum reservoir supplies one or several vacuum suction cups. This means that it is possible that the load could fall during lifting or transport. The area below the gripper and the load is always considered a danger zone.

With regard to the operator's operating and maintenance personnel, note that the operator must:

- Instruct the personnel in relation to the safety equipment in the system (for example, protective barriers or sensor systems)
- Monitor compliance with the safety measures
- Prevent unauthorized persons (not operating and maintenance personnel) from entering the defined danger zone of the system.

## 3 Design of vacuum reservoir VOL

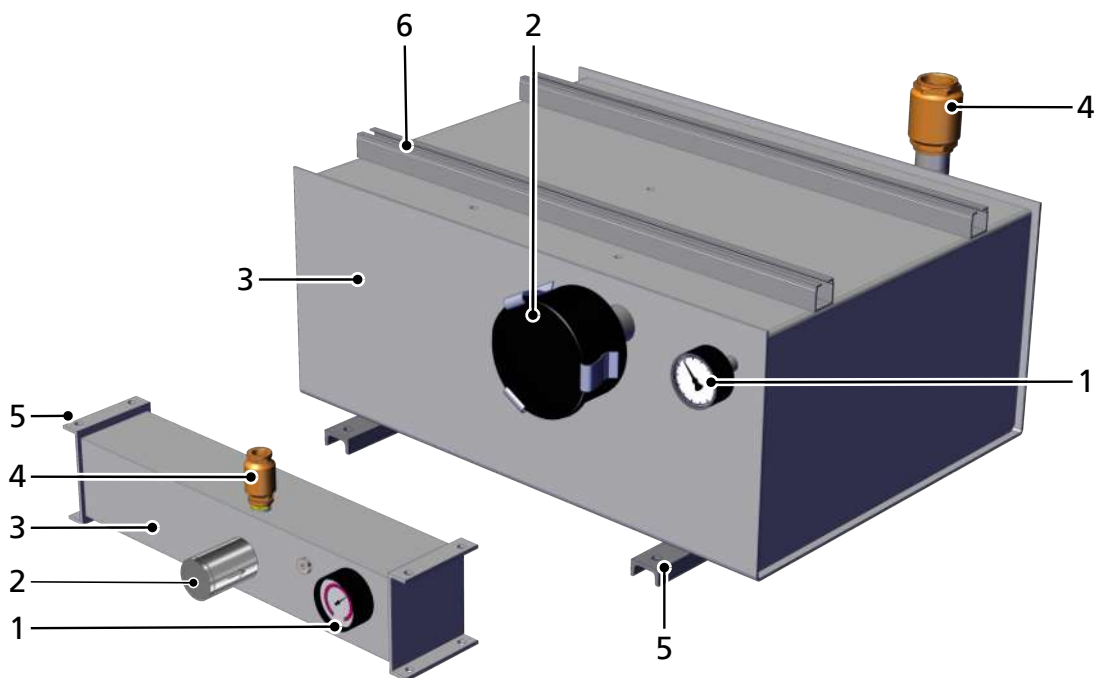

1	<b>Gauge</b>	2	Vacuum filter with suction connection gripper
3	Vacuum reservoir	4	<b>Non-return valve with vacuum pump connection</b>
5	Mounting holes	6	Mounting rail

The items in **bold print** have safety functions.

## 4 Technical Data

### 4.1 General Parameters

Type	Part no.	Capacity in l [liters]	Mass in kg [kilograms]
VOL 5	10.03.03.00108	5	8.0
VOL 15	10.03.03.00113	15	17.5
VOL 50	10.03.03.00118	50	35.5
VOL 100	10.03.03.00123	100	51.0
VOL 200	10.03.03.00128	200	97.0

### 4.2 Dimensions

#### VOL 5

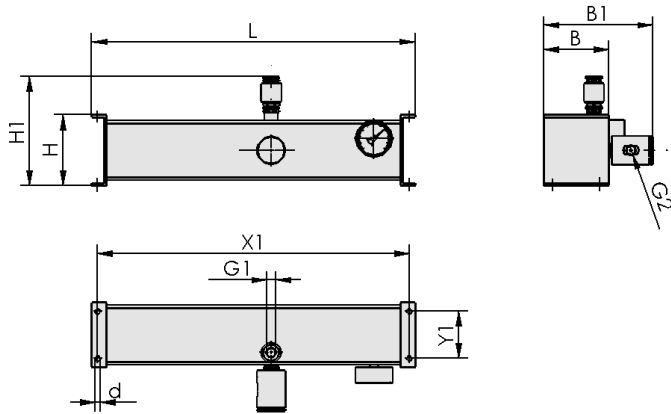

#### VOL 15–200

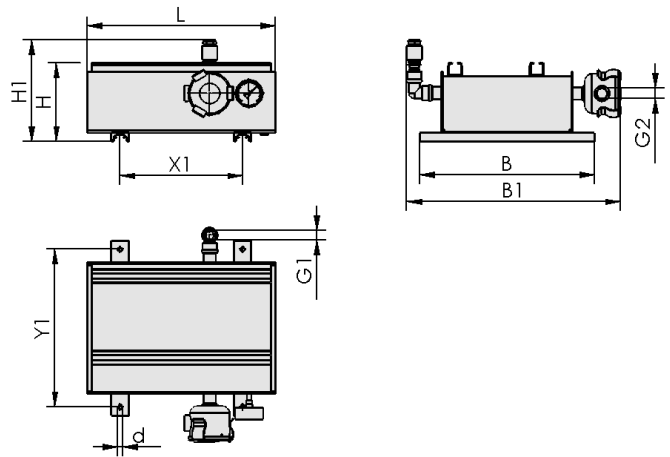

Type	B	B1	d	G1	G2	H	H1	L	X1	Y1
VOL 5	110	185	9	G3/8" female thread	G3/8" female thread	120	180	550	530	80
VOL 15	400	495	11	G1/2" female thread	G3/4" female thread	180	250	430	280	360
VOL 50	510	630	11	G3/4" female thread	G1-1/4" female thread	235	270	710	480	470
VOL 100	610	750	11	G1-1/4" female thread	G1-1/4" female thread	334	405	710	480	570
VOL 200	710	1015	11	G2" female thread	G2-1/2" female thread	434	495	910	592	670

## 5 Checking the Delivery

The scope of delivery can be found in the order confirmation. The weights and dimensions are listed in the delivery notes.

1. Compare the entire delivery with the supplied delivery notes to make sure nothing is missing.
2. Damage caused by defective packaging or occurring in transit must be reported immediately to the carrier and J. Schmalz GmbH.

## 6 Installation

### 6.1 Installation Instructions

For safe installation, the following instructions must be observed:



#### ⚠ CAUTION

##### Improper installation or maintenance

Personal injury or damage to property

- ▶ Before installation and maintenance work, the product must be depressurized (ventilated to the atmosphere).

1. Use only the connections, mounting holes and attachment materials that have been provided.
2. Carry out assembly or disassembly work only when the device is depressurized.
3. Pneumatic connections must be firmly connected to the vacuum reservoir and secured.

### 6.2 Transport

The vacuum reservoir (VOL 50–200) can be transported or set up with the aid of a suitable lifting crane and suitable lifting slings (note the maximum lift capacity of the lifting device).

### 6.3 Installation Site



#### ⚠ DANGER

##### Risk of fire and explosion due to switching components that are not explosion-proof

Serious injury or death!

- ▶ Do not use the product in environments where there is a risk of explosion.

The Vacuum reservoir must not be operated in rooms where there is a risk of explosion.

The ambient temperature must be between +5°C and +40°C. (Contact the manufacturer prior to operation if this range is to be exceeded).

Provide internal instructions and conduct checks to ensure that the area of the workplace is always clean and tidy.

### 6.4 Installation Procedure

- ▶ Screw the vacuum reservoir onto the installation site using fastening screws. To do so, use the mounting sockets or holes located on the reservoir.

### 6.5 Connecting the Vacuum Pump and Gripping System

1. Establish the connection to the vacuum pump via the G1 thread on the non-return valve using a suitable vacuum hose.
2. Establish the connection to the vacuum gripping system via the G2 thread on the vacuum filter using a suitable vacuum hose.

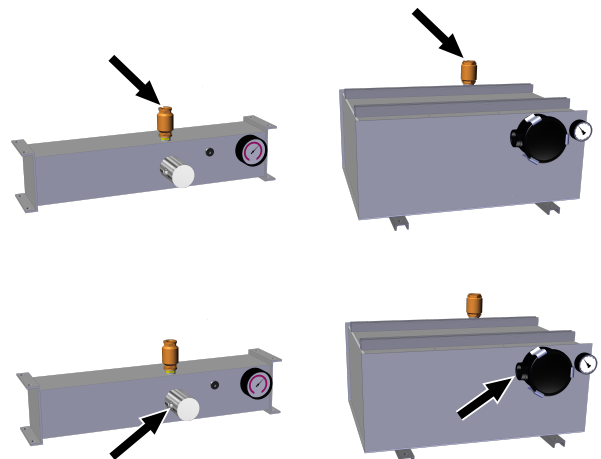

## 6.6 Safety Feature

As a safety feature, the vacuum reservoir is equipped with a pressure gauge indicating a red danger range indicator.

-  Check the safety features at the start of every shift (if the unit is not operated continuously) or once a week (if operated continuously).

### Checking the Vacuum Reservoir

1. Suction connection on the filter, e.g. with rubber sheet, vacuum-tight.
2. Switch on the vacuum pump and wait until a vacuum has been established.
3. Switch off the system and observe the pressure gauge. The vacuum should not drop by more than 100 mbar within 20 minutes.

-  Rectify faults before the device is put into operation. Should faults occur during operation, switch off the device and rectify the faults.

## 7 Starting Up the Device

Local applicable safety regulations must be observed.

The operator of the vacuum reservoir must take internal measures to ensure that:

- The users of the device are trained
- They have read and understood the operating instructions
- The operating instructions are accessible to them at all times

The responsibilities for the various tasks to be carried out on the device must be clearly specified and adhered to. The operating company must ensure that they have the appropriate qualifications and skills.

The following note is a supplement to local applicable safety regulations:

1. Regularly check the gauge.
  - ⇒ If the pressure gauge needle reaches the red area below -0.6 bar, there is a risk that the suction cups supplied by the vacuum reservoir can no longer safely hold the lifted load.
2. Check device for leaks.



### DANGER

#### Falling objects due to insufficient vacuum supply to the system

Risk of severe injury or death as the lifted load is no longer safely held.

- ▶ Standing or sitting under the lifted load is prohibited!
- ▶ Complete the work step as safely as possible
- ▶ Shut down supply
- ▶ Check device for leaks

## 8 Maintenance and Cleaning

### 8.1 Filter



### NOTE

#### When removing the filter cartridge, dust gets into the lines.

Damage to the vacuum generator

- ▶ When removing the filter cartridge, ensure that no dust enters the lines.
- ▶ Do not knock out the filter cartridge.



Check the filters at least once a week or in the event of dust accumulation, and blow the filter cartridge clear (from the inside to the outside).

Replace the filter cartridge if it is very dirty.

## 9 Troubleshooting

This device should only be installed and maintained by qualified specialist personnel. Check the safety features after repair or maintenance work is performed.

Fault	Possible cause	Solution
Pump runs, but vacuum does not reach -0.6 bar.	Filter cover leaking	▶ Check the filter cover for leaks.
	Blind plug leaking at the reservoir	▶ Tighten blind plug, replace sealing ring.
	Screw unions not tight	▶ Check screw unions, retighten and, if necessary, replace sealing rings.

## 10 Warranty

This system is guaranteed in accordance with our general terms of trade and delivery. The same applies to spare parts, provided that these are original parts supplied by us.

We are not liable for any damage resulting from the use of non-original spare parts or accessories.

The exclusive use of original spare parts is a prerequisite for the proper functioning of the system and for the validity of the warranty.

Wearing parts are not covered by the warranty.

## 11 Spare and Wearing Parts

Designation	VOL 5	VOL 15	VOL 50	VOL 100	VOL 200
<b>Spare parts</b>					
Non-return valve RSV	10.05.05.00002	10.05.05.00003	10.05.05.00004	10.05.05.00006	10.05.05.00008
Vacuum gauge VAM	10.07.02.00003				
<b>Wearing parts</b>					
Replacement filter cartridge FILT-EINS	10.07.01.00014	10.07.01.00017	10.07.01.00018		10.07.01.00020

## 12 Disposing of the Product

Recover the disassembled parts for recycling or reuse (provided no agreement on return or disposal has been made).

1. Dispose of the product properly after replacement or decommissioning.
2. Observe the country-specific guidelines and legal obligations for waste prevention and disposal.

## 13 EC Declaration of Conformity

### EC Declaration of Conformity

The manufacturer Schmalz confirms that the vacuum reservoir VOL product described in these operating instructions fulfills the following applicable EC directives:

2006/42/EC | Machinery Directive

The following harmonized standards were applied:

EN ISO 12100:2010	Safety of Machinery – Basic concepts, general principles for design – risk assessment
EN ISO 4414	Pneumatic fluid power – General rules and safety requirements for systems and their components