



Vacuum Block VCBL-G-K1

Operating Instructions

Note

The Operating instructions were originally written in German. Store in a safe place for future reference. Subject to technical changes without notice. No responsibility is taken for printing or other types of errors.

Published by

© J. Schmalz GmbH, 04/20

This document is protected by copyright. J. Schmalz GmbH retains the rights established thereby. Reproduction of the contents, in full or in part, is only permitted within the limits of the legal provisions of copyright law. Any modifications to or abridgments of the document are prohibited without explicit written agreement from J. Schmalz GmbH.

J. Schmalz GmbH · Johannes-Schmalz-Str. 1 · 72293 Glatten, Germany · T: +49 7443 2403-0
schmalz@schmalz.de

1 Important Information

1.1 Note on Using this Document

J. Schmalz GmbH is generally referred to as Schmalz in these Operating instructions.

These Operating instructions contain important notes and information about the different operating phases of the product:

- Transport, storage, start of operations and decommissioning
- Safe operation, required maintenance, rectification of any faults

The Operating instructions describe the product at the time of delivery by Schmalz.

1.2 The technical documentation is part of the product

1. For problem-free and safe operation, follow the instructions in the documents.
 2. Keep the technical documentation in close proximity to the product. The documentation must be accessible to personnel at all times.
 3. Pass on the technical documentation to subsequent users.
- ⇒ Failure to follow the instructions in these Operating instructions may result in injuries!
- ⇒ Schmalz is not liable for damage or malfunctions that result from failure to heed these instructions.

If you still have questions after reading the technical documentation, contact Schmalz Service at:

www.schmalz.com/services

1.3 Warnings in This Document

Warnings warn against hazards that may occur when handling the product. This document contains three levels of danger that you can recognize by the signal word.

Signal word	Meaning
WARNING	Indicates a medium-risk hazard that could result in death or serious injury if not avoided.
CAUTION	Indicates a low-risk hazard that could result in minor or moderate injury if not avoided.
NOTE	Indicates a danger that leads to property damage.

1.4 Symbol

 This symbol indicates useful and important information.

- ✓ This symbol represents a prerequisite that must be met prior to an operational step.
- ▶ This symbol represents an action to be performed.
- ⇒ This symbol represents the result of an action.

Actions that consist of more than one step are numbered:

1. First action to be performed.
2. Second action to be performed.

2 Fundamental Safety Instructions

2.1 Intended Use

The vacuum block VCBL-G-K1 is built in accordance with the latest standards of technology and is delivered in a safe operating condition; however, hazards may arise during use.

The vacuum block VCBL-G-K1 series is specially developed for use on the sealing plates of nesting machines. The vacuum blocks are used to secure the workpieces for mechanical processing. They can also be used to attach workpieces during manual mounting or machine processing.

The vacuum blocks are supplied with vacuum via separate vacuum connections on the machine.

The product is intended for use in the areas of industry, trade, and handcraft.

Intended use includes observing the technical data and the installation and operating instructions in this manual.

2.2 Non-Intended Use

Schmalz accepts no liability for damages resulting from use other than as intended. In particular, the following are considered non-intended use:

- Operation of the vacuum block with worn or damaged suction plate or sealing gasket
- Suction of human or animal body parts
- Machining forces that lead to the vacuum block and/or workpiece being displaced or torn off are not permitted.
- Use of the vacuum block as a base, support or comparable aid
- Use with workpieces at risk of explosion
- Evacuation of highly inflammable or explosive media
- Mechanical overload of the vacuum block
- Operation with a workpiece that does not cover the entire suction plate

2.3 Personnel Qualifications

Unqualified personnel cannot recognize dangers and are therefore exposed to higher risks!

1. Task only qualified personnel to perform the tasks described in this Operating instructions.
2. The product must be operated only by persons who have undergone appropriate training.

This Operating instructions is intended for fitters who are trained in handling the product and who can operate and install it.

2.4 Workplace Requirements

The following requirements must be fulfilled to ensure a safe workplace:

- The Vacuum block must not be used outdoors.
- The type plate and warning signs must be legible.
- The surroundings of the Vacuum block must be dry.
- The operator must have a clear view of the whole working area, the workplace must be adequately lit and free of glare, and the area around the workplace must be clean and clear.

2.5 Emissions

The Vacuum block emits noise as a result of operating with vacuum.



CAUTION

Noise pollution from leakage

Hearing damage

- ▶ Correct position.
- ▶ Wear ear protectors.

2.6 Modifications to the Product

Schmalz assumes no liability for consequences of modifications over which it has no control:

1. The product must be operated only in its original condition as delivered.
2. Use only original spare parts from Schmalz.
3. The product must be operated only in perfect condition.

3 Design of the Vacuum Block

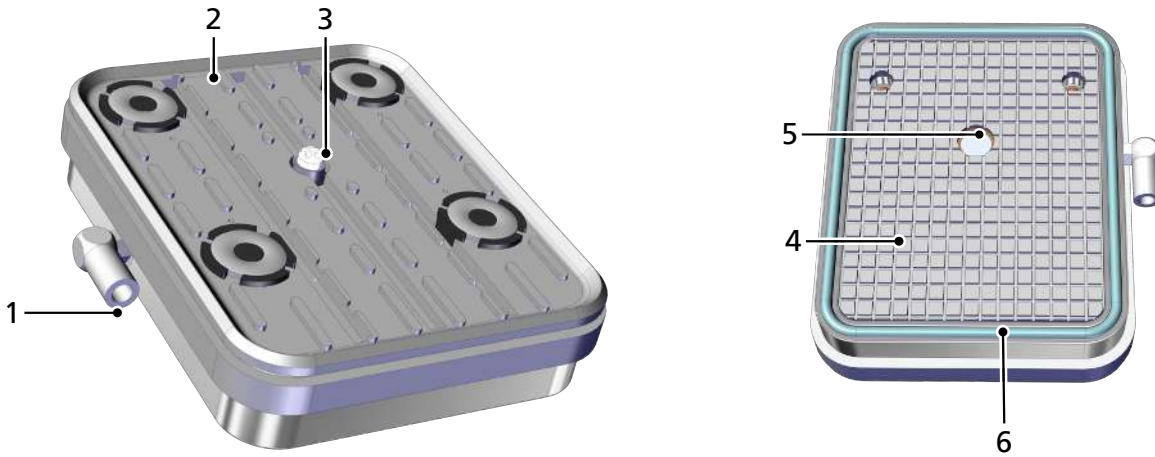

1	Hose connection (vacuum)	2	Suction plate
3	Touch valve	4	Friction pad
5	Screen	6	Sealing frame

4 Technical Data

4.1 General Parameters

Parameter	Unit	Value
Mass	kg	0.34
Hose diameter	mm	4
Maximum ambient temperature	°C	5 ... 45

4.2 Dimensions

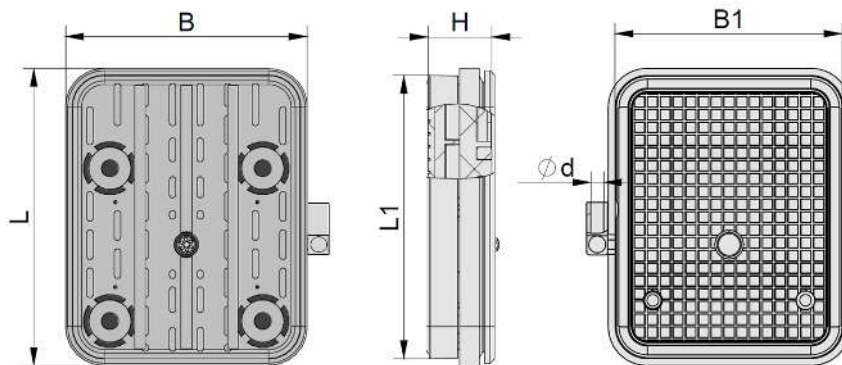

Part no.	L	L1	B	B1	H	Ød
10.01.12.03766	140	133	114	107	30	6

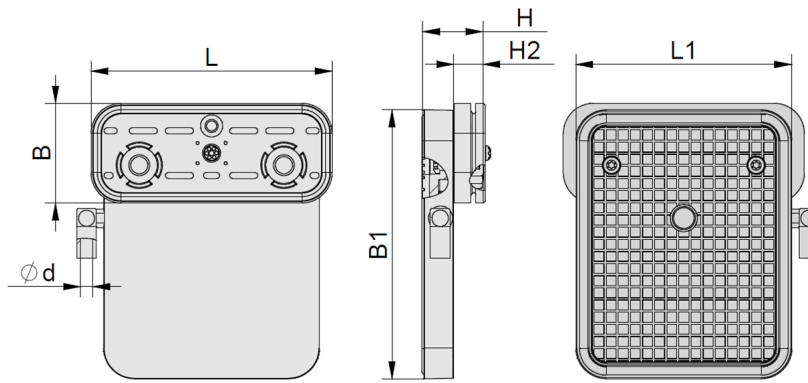

Part no.	L	L1	B	B1	H	H2	Ød
10.01.12.03776	120	107	50	133	30	14.5	6

All specifications are in mm.

5 Transport and Storage

5.1 Checking the Delivery

The scope of delivery can be found in the order confirmation. The weights and dimensions are listed in the delivery notes.

1. Compare the entire delivery with the supplied delivery notes to make sure nothing is missing.
2. Damage caused by defective packaging or occurring in transit must be reported immediately to the carrier and J. Schmalz GmbH.

6 Installation

6.1 Installation Instructions



⚠ CAUTION

Vacuum close to the eye

Severe eye injury!

- ▶ Wear eye protection.
- ▶ Do not look into vacuum openings, e.g. suction cups.

Take note of the following when mounting:

- Dirt particles or foreign bodies in the connections, hoses or pipelines or in the interface to the vacuum block can lead to malfunctions or failure.
- Shorten the hoses and pipelines as much as possible.
- Evacuation time is increased if the selected internal diameter of the hoses or pipelines is too short.
- Hose lines must be laid without bends or crimps.

6.2 Connecting the Vacuum

- ▶ Connect the vacuum hose with an outside diameter of 6 mm to the hose connection (1) with a plug-in screw union.

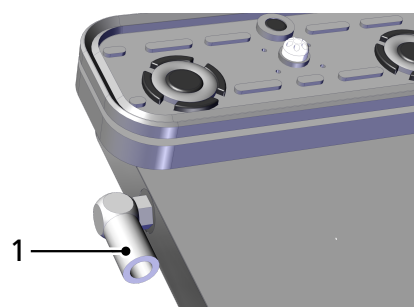

7 Specifications for Use



CAUTION

During machining, dust is released into the environment and can enter the respiratory tract.

Danger to health

- ▶ Use suction equipment or cover the machining area to ensure that no dust is released into the environment.
- ▶ If necessary, wear a breathing mask in accordance with class FFP1 or higher.

1. Monitor the vacuum value that is reached as close as possible to the vacuum block (e.g. with a gauge).
2. Ensure that the operating vacuum is ≥ 600 mbar before machining the workpiece.
3. Before each machining process, clean chips and dust from the nesting table and vacuum block to achieve the required accuracy and adhesion as well as to prevent leakage.
4. Check the sealing gaskets for wear and replace if necessary.

8 Using the Vacuum Blocks

For each suction process, check whether all the vacuum blocks used are securely fixed on the sealing plate and whether the workpiece is also sufficiently fixed before starting the machining operation.

The vacuum block must only be placed on the sealing plate with the friction pad facing downwards and with the vacuum switched off.

Only spare and wear parts approved by J. Schmalz GmbH may be used.

1. When the operating vacuum is switched on, the area between the vacuum block and the sealing plate is evacuated, thus fixing the vacuum block in place.
2. When the plate-shaped workpiece is placed on the suction plate, the touch valve of the vacuum block is actuated and the vacuum circuit is opened, thus fixing the workpiece.
Please note that the suction plate must be completely covered.
3. Before starting the machining process, check that the vacuum block and workpiece are securely fastened.
4. The workpiece can be machined.
5. The workpiece is released from the vacuum block and the vacuum block is released from the sealing plate when the operating vacuum is switched off.
6. The workpiece can now be removed.

9 Machining Limitations



WARNING

The workpiece comes loose during machining and is flung away by the machine.

Risk of injury from flying parts.

- ▶ Ascertain the maximum machining parameters and observe them.

The holding force is limited, meaning that it can withstand machining forces only up to a certain point. Accordingly, the operator of the vacuum block is obligated to establish for themselves (by experiment, slowly and carefully increasing the machining forces) the optimal settings and number of vacuum blocks necessary to ensure that the workpiece does not slip or even come loose during the machining process.

This procedure should be performed in particular for new workpieces that have never been machined before or for uncertain cases with regard to the holding force.

Schmalz assumes no liability for damages resulting from slippage or release of workpieces due to faulty adjustment of machining parameters.

10 Warranty

This system is guaranteed in accordance with our general terms of trade and delivery. The same applies to spare parts, provided that these are original parts supplied by us.

Wearing parts are not covered by the warranty.

11 Maintenance and Cleaning

11.1 Cleaning the Vacuum Blocks

1. For cleaning, do not use aggressive cleaning agents such as industrial alcohol, white spirit or thinners.
2. Remove dirt on the exterior of the device with a soft cloth and soap suds.

11.2 Replacing the Suction Plate and Touch Valve



NOTE

Sharp objects cause damage to rubber components.

Damage and malfunction

- ▶ Do not use sharp objects (e.g. screwdriver, etc.) to mount or disassemble rubber components.

The suction plate and touch valve become more or less worn depending on their application and are thus considered wearing parts. The following section describes how to replace them.

Removing the Suction Plate From the Touch Valve if Necessary:

1. Pull a corner of the suction plate over the edge of the black suction cup connection plate and completely remove it.
2. If the touch valve needs to be replaced, pull it out of the mounting hole with a gripper.



Mounting the New Suction Plate and Touch Valve:

1. Place the new touch valve on the bore hole provided in the suction cup connection plate and press it in.



- ⇒ The touch valve must be approx. 9.7 mm above the suction cup connection plate.

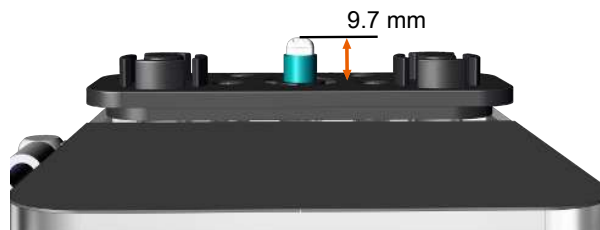

- Place the new suction plate over the touch valve and pull it over the suction plate of the suction cup connection plate one edge at a time. The suction plate must be underneath the suction cup connection plate at all points.

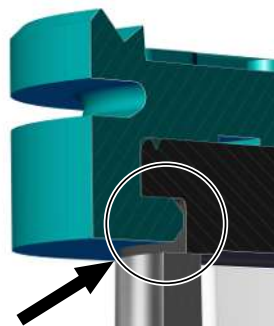

12 Spare and wearing parts

Part no.	Type	Designation	Part type
10.01.12.00012	VCSP-O 120x50x15.5	Suction plate For VCBL-G-K1 120x50x30 (10.01.12.03776)	Wearing part
10.01.12.00228	VCSP-U 140x115x16.5 VCBL-K1	Suction plate For VCBL-G-K1 140x115x30 (10.01.12.03766)	Wearing part
10.01.12.02514	TV D9 4.3	Touch valve with plastic spring plunger	Wearing part
10.08.02.00235	STV-W M5-AG 6	Plug-in screw union bracket (hose D6)	Spare part
10.08.02.00155	STV-W M5-AG 4	Plug-in screw union bracket (hose D4)	Spare part
10.01.12.04512	DI-SCHNx423 MOS NK	Sealing gasket	Wearing part

13 Disposing of the product

- ▶ Sort and dispose of all components according to the country-specific regulations.

i For proper disposal, please contact a company specializing in the disposal of technical goods and instruct the company to observe the applicable disposal and environmental regulations. Schmalz is happy to assist you in finding a suitable company.

14 Notes