

技術資料 Technische Documentatie **Documentation**  
Documentação técnica Documentación técnica Documentazione tecnica  
**Technische Dokumentation** Technical Documentation Техническая документация  
Documentazione tecnica Technische documentatie  
Техническая документация **Teknik Doküman** 技术资料  
**Documentazione tecnica** Dokumentacja techniczna  
**Technische documentatie** Documentación técnica 技術資料  
기술 자료 Technische documentatie 技術資料  
Documentation technique Teknik Doküman Dokumentacja techniczna  
Technical Documentation **Documentazione tecnica** Technical Documentation  
**Dokumentacja techniczna** 技术资料 Documentation technique  
Техническая документация Technische Dokumentation **Teknik Doküman**  
Dokumentacja techniczna Technische documentatie  
Documentation technique 기술 자료 Dokumentacja techniczna



Vacuum/pressure switch VS-V/P-W-D K 3C-D

# Operating Instructions

**Note**

The Operating instructions were originally written in German. Store in a safe place for future reference. Subject to technical changes without notice. No responsibility is taken for printing or other types of errors.

**Published by**

© J. Schmalz GmbH, 11/19

This document is protected by copyright. J. Schmalz GmbH retains the rights established thereby. Reproduction of the contents, in full or in part, is only permitted within the limits of the legal provisions of copyright law. Any modifications to or abridgments of the document are prohibited without explicit written agreement from J. Schmalz GmbH.

**Contact**

J. Schmalz GmbH  
Johannes-Schmalz-Str. 1  
72293 Glatten, Germany  
T: +49 7443 2403-0  
schmalz@schmalz.de  
www.schmalz.com

Contact information for Schmalz companies and trade partners worldwide can be found at:  
[www.schmalz.com/salesnetwork](http://www.schmalz.com/salesnetwork)

# Contents

<b>1</b>	<b>Important Information</b>	<b>5</b>
1.1	Note on Using this Document	5
1.2	The technical documentation is part of the product	5
1.3	Warnings in This Document	5
1.4	Symbol	5
<b>2</b>	<b>Fundamental Safety Instructions</b>	<b>6</b>
2.1	Intended use	6
2.2	Non-Intended Use	6
2.3	Personnel Qualification	6
2.4	Modifications to the Product	6
<b>3</b>	<b>Product Description</b>	<b>7</b>
3.1	Variants and Type Key	7
3.2	Design of vacuum/pressure switch	7
3.3	Display and Operating Element in Detail	8
<b>4</b>	<b>Technical Data</b>	<b>9</b>
4.1	General Parameters	9
4.2	Dimensions	10
<b>5</b>	<b>Installation</b>	<b>11</b>
5.1	Mounting	11
5.2	Pneumatically Connecting the Switch	11
5.3	Electrical Connection	11
<b>6</b>	<b>Operation</b>	<b>13</b>
6.1	Safety Instructions	13
6.2	Setting Up the Basic Functions	13
6.3	Functions in the Main Menu	13
6.4	Functions in the Additional Functions Menu	14
6.5	Energy-Saving Function	15
6.6	Setting the Zero Point	15
6.7	Setting the Vacuum or Pressure Unit	16
6.8	Setting the Switching Point	16
6.8.1	Setting the Switching Points for One Output	16
6.8.2	Setting the Switching Points for Two Outputs	17
6.9	Locking the Keypad	18
6.10	Displaying the Maximum and Minimum Values of the Measured Values	18
6.11	Fine Adjustment of the Display Values	19
6.12	Switching Logic	20
6.13	Voltage Profiles of the Analog Output	20
<b>7</b>	<b>Troubleshooting</b>	<b>21</b>
<b>8</b>	<b>Accessories</b>	<b>22</b>
8.1	Accessory Items	22
8.2	Mounting Accessories	22

**9 EC Declaration of Conformity ..... 24**

# 1 Important Information

## 1.1 Note on Using this Document

J. Schmalz GmbH is generally referred to as Schmalz in these Operating instructions.

These Operating instructions contain important notes and information about the different operating phases of the product:

- Transport, storage, start of operations and decommissioning
- Safe operation, required maintenance, rectification of any faults

The Operating instructions describe the product at the time of delivery by Schmalz.

## 1.2 The technical documentation is part of the product

1. For problem-free and safe operation, follow the instructions in the documents.
2. Keep the technical documentation in close proximity to the product. The documentation must be accessible to personnel at all times.
3. Pass on the technical documentation to subsequent users.
  - ⇒ Failure to follow the instructions in these Operating instructions may result in life-threatening injuries!
  - ⇒ Schmalz is not liable for damage or malfunctions that result from failure to heed these instructions.

If you still have questions after reading the technical documentation, contact Schmalz service at:

[www.schmalz.com/services](http://www.schmalz.com/services)

## 1.3 Warnings in This Document

Warnings warn against hazards that may occur when handling the product. This document contains three levels of danger that you can recognize by the signal word.

Signal word	Meaning
WARNING	Indicates a medium-risk hazard that could result in death or serious injury if not avoided.
CAUTION	Indicates a low-risk hazard that could result in minor or moderate injury if not avoided.
NOTE	Indicates a danger that leads to property damage.

## 1.4 Symbol



This symbol indicates useful and important information.

- ✓ This symbol represents a prerequisite that must be met prior to an operational step.
- ▶ This symbol represents an action to be performed.
- ⇒ This symbol represents the result of an action.

Actions that consist of more than one step are numbered:

1. First action to be performed.
2. Second action to be performed.

## 2 Fundamental Safety Instructions

### 2.1 Intended use

The Vacuum/pressure switch is used for measuring and displaying vacuum power or pressure and outputs it proportionally as an electrical voltage from 1 to 5 V on an analog output.

This device has been designed, developed and constructed solely for industrial and commercial use. Private use is excluded.

The Vacuum/pressure switch is built in accordance with the latest standards of technology and is shipped in safe condition. However, hazards can arise during use.

Intended use includes the observance of the technical data and the installation and operating instructions in this manual.

### 2.2 Non-Intended Use

Schmalz accepts no liability for damages caused by the use of the Vacuum/pressure switch for purposes other than those described under "Intended Use."

Non-intended use includes the following:

- Use in potentially explosive atmospheres

### 2.3 Personnel Qualification

Unqualified personnel cannot recognize dangers and are therefore exposed to higher risks!

1. Only instruct qualified personnel to perform the tasks described in these operating instructions.
2. The product may only be operated by persons who have undergone appropriate training.
3. Electrical work and installations may only be carried out by qualified electrical specialists.
4. Assembly and maintenance work must only be carried out by qualified personnel.

### 2.4 Modifications to the Product

Schmalz assumes no liability for consequences of modifications over which it has no control:

1. The product must be operated only in its original condition as delivered.
2. Use only original spare parts from Schmalz.
3. The product must be operated only in perfect condition.

## 3 Product Description

### 3.1 Variants and Type Key

The product description of the Vacuum/pressure switch is composed of the following type key:

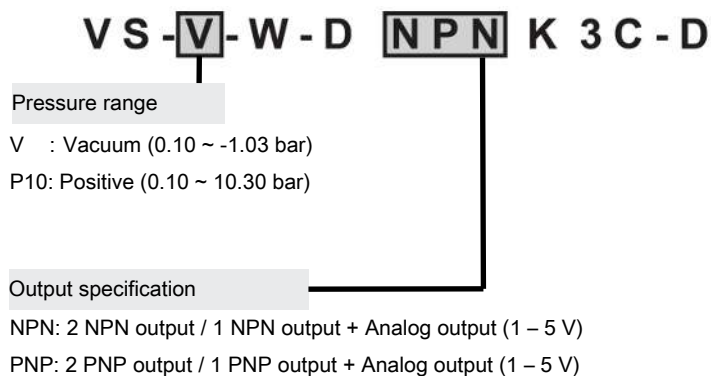

Part no.	Type key	Pressure range	Outputs
10.06.02.00678	VS-V-W-D PNP K 3C-D	Vacuum (-1.03 to 0.10 bar)	2 PNP
10.06.02.00679	VS-V-W-D NPN K 3C-D	Vacuum (-1.03 to 0.10 bar)	2 NPN
10.06.02.00680	VS-P10-W-D PNP K 3C-D	Pressure (0.10 to 10.30 bar)	2 PNP
10.06.02.00681	VS-P10-W-D NPN K 3C-D	Pressure (0.10 to 10.30 bar)	2 NPN
10.06.02.00719	VS-V-W-D PNP K 3C-D	Vacuum (-1.03 to 0.10 bar)	PNP / 1...5 V
10.06.02.00720	VS-V-W-D NPN K 3C-D	Vacuum (-1.03 to 0.10 bar)	NPN / 1...5 V
10.06.02.00721	VS-P10-W-D PNP K 3C-D	Pressure (0.10 to 10.30 bar)	PNP / 1...5 V
10.06.02.00722	VS-P10-W-D NPN K 3C-D	Pressure (0.10 to 10.30 bar)	NPN / 1...5 V

### 3.2 Design of vacuum/pressure switch

1	UP BUTTON
2	Display
3	DOWN BUTTON
4	SET BUTTON
5	Electrical connection/connection cable
6	Measuring medium
7	O-ring
8	Mounting thread 2xM5

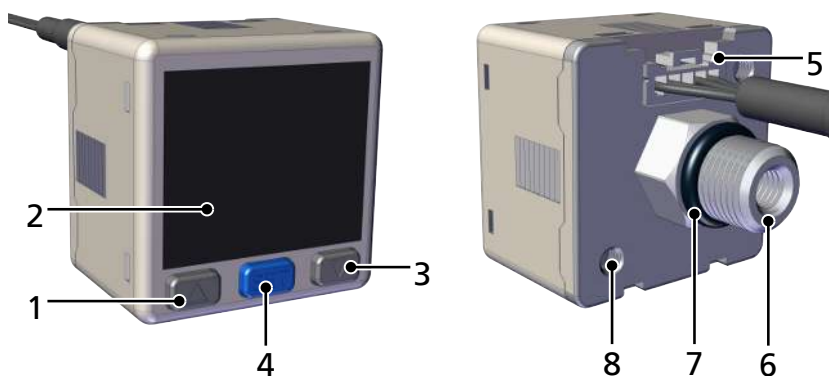

### 3.3 Display and Operating Element in Detail

The Vacuum/pressure switch display and operating element features 3 buttons and two display areas.

1	Display for output 1
2	Display for output 2
3	Lock indicator
4	Unit for pressure display
5	Main display area, two-colored
6	Setting mode of lower display area
7	<b>DOWN BUTTON</b>
8	<b>SET BUTTON</b>
9	<b>UP BUTTON</b>

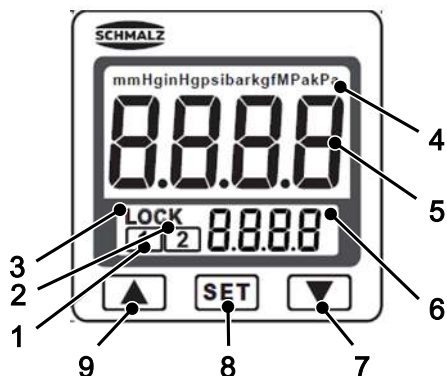

Pressure definition with selected display unit depending on the vacuum switch version:

Selected unit	Display definition for variant VS-V...	Display definition for variant VS-P10...
kPa	0.1	—
MPa	—	0.001
kgf/cm <sup>2</sup>	0.001	0.01
bar	0.001	0.01
psi	0.01	0.1
inHg	0.1	—
mmHg	1	—



## 4 Technical Data

### 4.1 General Parameters

Parameter	Unit	Value for VS-V...	Value for VS-P10...
Measuring medium	—	Non-aggressive, flammable gases; dry, oil-free air	
Measurement range	bar	-1.03...0.00	0.00...10.3
Adjustable range	bar	-1.03...0.10	0.10...10.3
Max. overpressure resistance	bar	5	15
Factory setting	bar	H1: -0.75 L1: -0.60 H2: -0.55 L2: -0.50 NO mode	H1: 5.50 L1: 5.00 H2: 5.00 L2: 4.50 NO mode
Supply voltage	—	12 to 24 V DC $\pm$ 10%, ripple (P-P) 10% or less	
Current consumption	mA	$\leq$ 30 (without load)	
Switching output, type	—	Open collector 2 outputs (NPN or PNP)	
Switching output, electricity	mA	Max. 100	
Switching output, residual voltage	V	$\leq$ 1	
Resistance, output	k $\Omega$	1	
Voltage, output	V	1 ~ 5 $\pm$ 2.5% F.S.	
Linearity, output	—	—	
Switching output, response time	ms	$\leq$ 2.5 (can be set to 25, 100, 250, 500, 1000 and 1500)	
Display	—	2-color main display (red/green); 1-color additional display (orange), sample rate: 0.2, 0.5, 1 second / time selectable	
Display accuracy	—	$\pm$ 1% F.S. $\pm$ 1 digit (ambient temperature: 25 $\pm$ 3° C)	
Repeatability (switching output)	—	$\pm$ 0.3% F.S. $\pm$ 1 digit	
Vacuum/pressure switch display switched on	—	Orange OUT display	
Degree of protection IP	—	IP40	
Operating temperature	° C	0 ... 50	
Temperature characteristic	° C	$\pm$ 2% F.S. of the recorded pressure (25° C) for a temperature range of 0 ... 50	
Storage temperature	° C	-10 ... 60 (no condensation, not freezing)	
Permitted humidity	% RH	35 ... 85 (no condensation)	
Withstand voltage	—	1000 V AC in 1 min. (between housing and connection cable)	
Insulation resistance	—	50 M $\Omega$ (at 500 V DC, between housing and connection cable)	
Vibration	—	Total amplitude 1.5 mm, 10 Hz ~ 150 Hz ~ 10 Hz for 1 minute, two hours in each direction X, Y and Z	
Shock strength	—	100 m/s <sup>2</sup> (10G), 3 times each in the direction of X, Y and Z	

Parameter	Unit	Value for VS-V...	Value for VS-P10...
Measuring medium connection	—	1/8" external thread	
Electrical connection	—	Oil-resistant cable (0.15 mm <sup>2</sup> ), 4-pole	
Weight	g	Approx. 67 (incl. 2-m cable)	

## 4.2 Dimensions

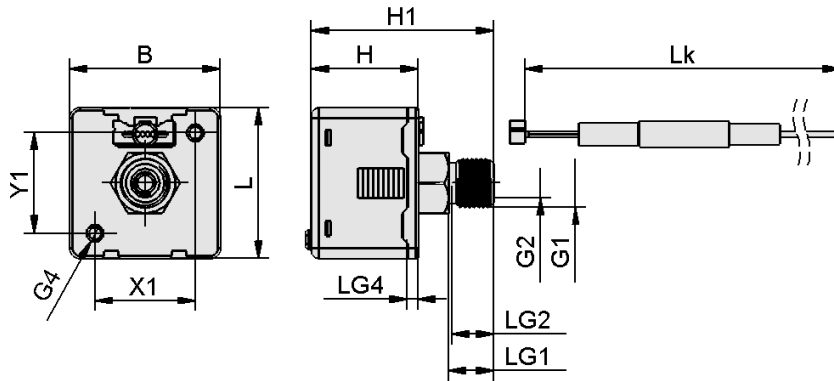

B	G1	G2	G4	H	H1	L	LG1	LG2	LG4	Lk	X1	Y1
30	1/8" external thread	M5 internal thread	M3 internal thread	21.3	36.3	30	9	10	4.5	2000	20	20

All specifications are in mm

## 5 Installation

### 5.1 Mounting

The sensor may be installed in any position.

To ensure correct function and to prevent faults in the sensor, observe the following installation instructions:

Do not drop the vacuum/pressure switch and do not subject it to excessive impacts. Even if the switch housing is undamaged, internal components may be damaged, resulting in malfunction.

- ✓ Two M5 fastening screws are provided by the customer.

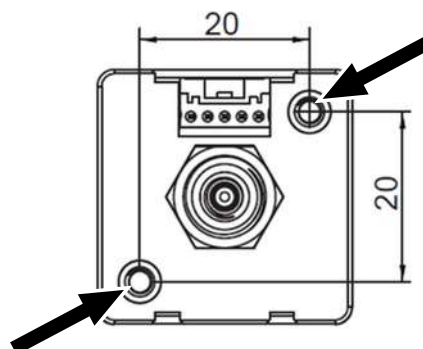

- ▶ Attach the vacuum/pressure switch with two M5 threads.



The length of the screws must be limited to 5 mm. Do not use standard screws!

### 5.2 Pneumatically Connecting the Switch

- ▶ The pneumatic connection uses a G1 or G2 thread. Connect suitable pipelines with the appropriate connection. To connect the hex socket or connector, hold the hexagonal part of the pneumatic connector tight and secure it. Use a tightening torque of 13 Nm or less.

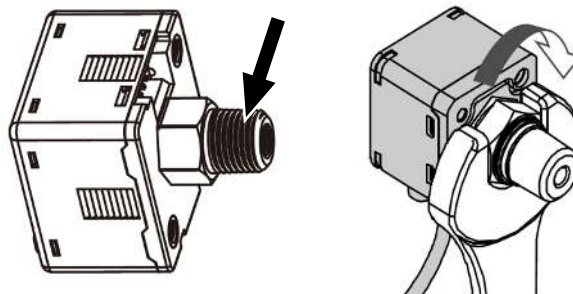

### 5.3 Electrical Connection



#### NOTE

##### Incorrect power supply

Destruction of the integrated electronics

- ▶ Operate the product using a power supply unit with protected extra-low voltage (PELV).
- ▶ The system must incorporate safe electrical cut-off of the power supply in compliance with EN60204.
- ▶ Do not connect or disconnect the connector under tension and/or when voltage is applied.



**NOTE**

**Connect with the power turned on**

Damage to the electronics and/or malfunction

- ▶ Switch off the power supply before connecting cables!

The vacuum/pressure switch is supplied with a 4-wire connection cable with open cable ends.

Integrate the vacuum/pressure switch into your application in accordance with the electrical circuit diagram.

**Electrical Circuit Diagrams**

VS-□-W-D NPN K 3C-D (1 NPN+Analog Output (1 – 5 V))

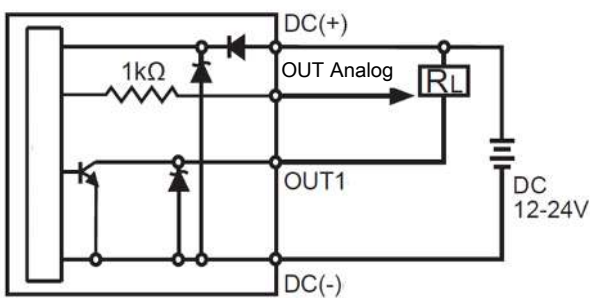

VS-□-W-D PNP K 3C-D (1 PNP+Analog Output (1 – 5V))

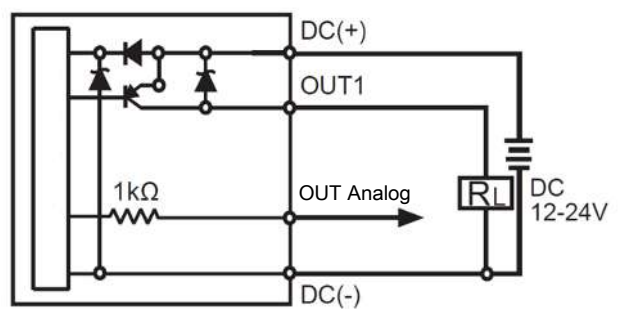

VS-□-W-D NPN K 3C-D (2 NPN Output)

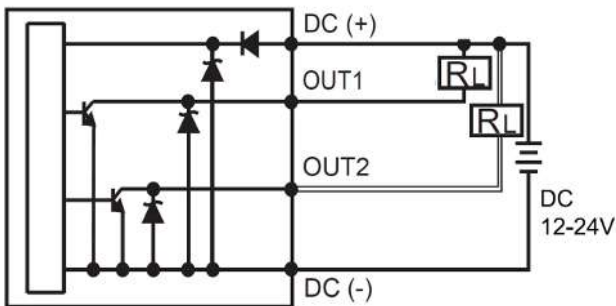

VS-□-W-D PNP K 3C-D (2 PNP Output)

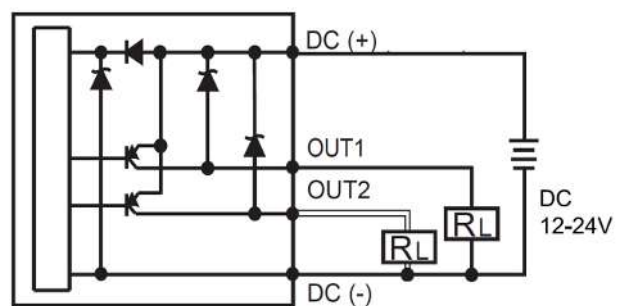

**Assignment of Cable Colors**

Cable	Cable color
DC (+)	Brown
OUT1	Black
OUT2 / OUT Analog	White
DC (-)	Blue

Lay the connection cables of the pressure switch separately. Electrical interference can cause malfunctions if the cable is routed together with mains or high voltage cables.

Establish a ground connection when using a standard cable.

When the switching regulator is connected to the pressure switch, the switching signals are superimposed and the product specification is no longer fulfilled. This can be prevented by inserting a noise filter (mains noise filter, ferrite element) between the switching regulator and the pressure switch, or by using a serial power supply instead of a switching regulator.

## 6 Operation

### 6.1 Safety Instructions



#### NOTE

#### Operating pressure above the recommended maximum pressure

Damage to the switch

- ▶ Only use the Vacuum/pressure switch within the nominal pressure range.

Do not drop the vacuum switch or subject it to impacts.

Even if the housing is undamaged, internal components may be damaged and cause malfunction.

### 6.2 Setting Up the Basic Functions

The Vacuum/pressure switch is operated using three buttons:

	SET BUTTON
	UP BUTTON
	DOWN BUTTON

Settings are configured in software menus.

The following menus are available:

- Main menu: For standard applications
- Additional Functions menu: For applications with special requirements

#### Activating the Main Menu and Selecting Parameters

- ✓ The Vacuum/pressure switch is in Measurement mode.
1. Press the button for at least three seconds.
    - ⇒ The first parameter in the main menu is selected. This is indicated by  $\square \text{E} \text{I}$  in the lower display.
  2. Press the or button to select the desired function mode for the OUT1 output.
  3. By pressing the button, the next parameter is selected and the selected or set parameter value is accepted.

### 6.3 Functions in the Main Menu

The following table shows an overview of the display codes and parameters in the main menu:

Parameter	Display code for the lower display	Display code for the main display	Explanation
OUT1 output operating mode	$\square \text{E} \text{I}$	$\square \text{PS}$	One point set mode
		$\text{HY} \text{S}$	Hysteresis mode
		$\text{U} \text{IN}$	Window Comparator mode
OUT1 output Switching logic	$\square \text{E} \text{I}$	$\text{NO}$	"normally open" NO mode
		$\text{NC}$	"normally open" NC mode
OUT2 output operating mode	$\square \text{E} \text{2}$	$\square \text{FF}$	Output 2 deactivated
		$\square \text{PS}$	One point set mode

Parameter	Display code for the lower display	Display code for the main display	Explanation
This selection will not be displayed if only one output is available. OUT2 output Switching logic This selection will not be displayed if only one output is available or if output 2 is deactivated (OFF).		HYS	Hysteresis mode
		U in	Window Comparator mode
		no	"normally open" NO mode
		nc	"normally open" NC mode
Response time	rES	2.5 25 100 250 500 1000 1500	2.5 ms 25 ms 100 ms 250 ms 500 ms 1000 ms 1500 ms
Display color	col	Sor SoG rEd Grn	ON: red, OFF: green ON: green, OFF: red ON/OFF: red ON/OFF: green
Display unit	uni	bAr GF PA PS i inH mmH	Shown in bar Shown in kgf/cm <sup>2</sup> Shown in kPa / MPa Shown in psi Shown in inHg <sup>1)</sup> Shown in mmHg <sup>1)</sup>

<sup>1)</sup> Only available for the vacuum and pressure/vacuum variants.

### 6.4 Functions in the Additional Functions Menu

#### Activating the Additional Functions Menu and Selecting Parameters

- ✓ The Vacuum/pressure switch is in Measurement mode.
- 1. Press the **SET** button for at least five seconds.
  - ⇒ The first parameter HYS is selected. This is indicated in the lower display.
- 2. Press the **▲** or **▼** button to select the desired hysteresis value.
- 3. By pressing the **SET** button, the next parameter is selected and the selected or set parameter value is accepted.

The following table shows an overview of the display codes and parameters in the Additional Functions menu:

Parameter	Display code for the lower display	Display code for the main display	Explanation
Hysteresis value	HYS	3,  -> 4, ..., 8, 1, 2	Fixed hysteresis setting
Display color OUT2 is not displayed if the output specification is set to one output.	dSP	oE1 oE2	Select the display color for output 1 Select the display color for output 2
Update time	rEF	200 500 1000	Update time can be set to 200, 500 or 1000 ms
Energy-saving function	oFF oN	SLP	Activate (oN) or deactivate (oFF) the energy-saving function (> See ch. Energy-Saving Function, Page 15)
Factory setting	oFF oN	rSt	Reset the Vacuum/pressure switch to factory settings (oN)
Fine Adjustments mode display	oFF oN	F in	Activate (oN) or deactivate (oFF) the energy-saving function (> See ch. Fine Adjustment of the Display Values, Page 19)

## 6.5 Energy-Saving Function

The Vacuum/pressure switch provides the option to switch off the display to save energy.

The energy-saving function is activated and deactivated in the Additional Functions menu using the SLP parameter.

The selected setting is shown in the lower display.

- Energy-saving function active, SLP = oN, the main display is switched off 30 seconds after the last key actuation and the lower display shows SLP. In Energy-Saving mode, the output LCD may not sync to the output. This is normal and does not affect the output operation.
- Energy-saving function inactive, SLP = oFF, the main display is permanently switched on.

Press any button to temporarily turn on the main display.

## 6.6 Setting the Zero Point

Since the production conditions for the integrated vacuum sensor can vary, we recommend calibrating the sensor once it is installed. To calibrate the vacuum sensor, the system's vacuum circuit must be open to the atmosphere.

Calibrate Vacuum/pressure switch, zero point = ambient pressure

1. Press the  +  button until "00" is displayed.

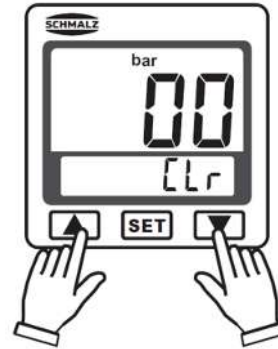

⇒ CLr is indicated in the lower display.

2. Release the buttons.

⇒ The Vacuum/pressure switch is set to zero.

### 6.7 Setting the Vacuum or Pressure Unit

The physical unit that is used to display the measured values as well as the limit values and hystereses on the main display can be set via the main menu under the menu item [ u r i ]:



Unit	Display code, setting parameters	Display unit
Pascal	PA	kPa/MPa
Kilogram-force per square centimeter	CF	kgf/cm <sup>2</sup>
bar	bAr	mbar
Pound-force per square inch	PSI	psi
Inches of mercury	inH	inHg
Millimeters of mercury	mmH	mmHg

### 6.8 Setting the Switching Point





 Do not disconnect the power supply when the lower display and setting value flash alternately. Otherwise, the system cannot save the values.

#### 6.8.1 Setting the Switching Points for One Output

Setting condition 1:

- OUT1 mode = "P5" (One point set mode)
- ✓ Measurement mode, P-1 and the currently set value are displayed alternately.
- ▶ P-1 Enter the switching point value with the  or  button.

Setting condition 2:

- OUT1 mode = "H5" (Hysteresis mode); "u in" Window Comparator mode
- ✓ Measurement mode, H-1 and the currently set value are displayed alternately.
- 1. H-1 Enter the switching point value with the  or  button.
- 2. Use the  button to change to switching point L-1.
- 3. L-1 Enter the switching point value with the  or  button.



## 6.8.2 Setting the Switching Points for Two Outputs

### Setting condition 1:

- OUT1 mode = "□P5" (One point set mode)
- OUT2 mode = "□FF" (not used)
- ✓ Measurement mode, P-1 and the currently set value are displayed alternately.
- ▶ P-1 Enter the switching point value with the ▲ or ▼ button.

### Setting condition 2:

- OUT1 mode = "□P5" (One point set mode)
- OUT2 mode = "□P5" (One point set mode)
- ✓ Measurement mode, P-1 and the currently set value are displayed alternately.
- 1. P-1 Enter the switching point value with the ▲ or ▼ button.
- 2. Use the SET button to change to switching point P-2.
- 3. P-2 Enter the switching point value with the ▲ or ▼ button.

### Setting condition 3:





- OUT1 mode = "□P5" (One point set mode)
- OUT2 mode = "HY5" (Hysteresis mode); "U in" Window Comparator mode
- ✓ Measurement mode, P-1 and the currently set value are displayed alternately.
- 1. P-1 Enter the switching point value with the ▲ or ▼ button.
- 2. Use the SET button to change to parameter L-2.
- 3. L-2 Enter the switching point value with the ▲ or ▼ button.
- 4. Use the SET button to change to switching point H-2.
- 5. H-2 Enter the switching point value with the ▲ or ▼ button.
- 6. Use the SET button to change to parameter P-1.

### Setting condition 4:











- OUT1 mode = "HY5" (Hysteresis mode); "U in" Window Comparator mode
- OUT2 mode = "□FF" (not used)
- ✓ Measurement mode, L-1 and the currently set value are displayed alternately.
- 1. L-1 Enter the switching point value with the ▲ or ▼ button.
- 2. Use the SET button to change to switching point H-1.
- 3. H-1 Enter the switching point value with the ▲ or ▼ button.

### Setting condition 5:

- OUT1 mode = "HY5" (Hysteresis mode); "U in" Window Comparator mode
- OUT2 mode = "□P5" (One point set mode)
- ✓ Measurement mode, L-1 and the currently set value are displayed alternately.
- 1. L-1 Enter the switching point value with the ▲ or ▼ button.





2. Use the **SET** button to change to switching point H- 1.
3. H- 1 Enter the switching point value with the  or  button.
4. Use the **SET** button to change to switching point P- 2.
5. P- 2 Enter the switching point value with the  or  button.
6. Use the **SET** button to change to parameter L - 1.

**Setting condition 6:**

- OUT1 mode = "HY5" (Hysteresis mode); "  in " Window Comparator mode
  - OUT2 mode = "HY5" (Hysteresis mode); "  in " Window Comparator mode
  - ✓ Measurement mode, L-1 and the currently set value are displayed alternately.
1. L - 1 Enter the switching point value with the  or  button.
  2. Use the **SET** button to change to switching point H- 1.
  3. H- 1 Enter the switching point value with the  or  button.
  4. Use the **SET** button to change to switching point L - 2.
  5. L - 2 Enter the switching point value with the  or  button.
  6. Use the **SET** button to change to parameter H- 2.
  7. H- 2 Enter the switching point value with the  or  button.
  8. Use the **SET** button to change to parameter L - 2.

**6.9 Locking the Keypad**

Use the keypad lock to prevent unauthorized or inadvertent changing of the switch setting.

- ✓ The Vacuum/pressure switch is in Measurement mode.
1. Press the  + **SET** button for at least two seconds.
    - ⇒ The Vacuum/pressure switch changes to the write protection function. This is indicated by **L**   in the main display.
  2. Press the  or  button to select the desired setting (**FF** or **FF**). This is indicated in the lower display.
  3. Use the **SET** button to save the selected setting and switch to Measurement mode.

When Lock mode (**L**   = **FF**) is selected, **LOCK** is displayed in the lower display.

**6.10 Displaying the Maximum and Minimum Values of the Measured Values**

In normal operation, the built-in memory will hold the highest and lowest reading recorded since the power was turned on.

Measured value	Display code
Minimum value	<b>bo-</b>
Maximum value	<b>PE-</b>

- ✓ The Vacuum/pressure switch is in Measurement mode.
- ▶ Press the **SET** + **▼** button for at least two seconds.
- ⇒ PE- is indicated in the main display
- ⇒ and b0- is indicated in the lower display.
- ⇒ The display changes and alternates between the measured values of the maximum and minimum measurements and the display codes.

Switch to Measurement mode.

- ▶ Press the **SET** button.

## 6.11 Fine Adjustment of the Display Values

This feature eliminates minor differences in the output values. With multiple switches this ensures a consistent display. The display values of the switch can be adjusted within  $\pm 2.5\%$ .

This function is activated and deactivated in the Additional Functions menu using the F 0 parameter.

- ✓ The Vacuum/pressure switch is in Measurement mode.
1. Press the **SET** button for at least five seconds.
    - ⇒ The Vacuum/pressure switch changes to the Additional Functions menu.
  2. Press the **SET** button until the F 0 parameter appears in the main display.
  3. Press the **▲** or **▼** button to activate (00) or deactivate (0FF) the function. The selected setting is shown in the lower display.
    - ⇒ The function is deactivated 0FF. Use the **SET** button to save the selected setting and switch to Measurement mode.
    - ⇒ The function is activated 00, proceed with the following steps.
  4. Press the **SET** button to change to Setting mode in the F 0 function.
    - ⇒ The display alternately shows the parameters and the values.
  5. Press the **▲** or **▼** button to set the value of the F5C parameter. The F5C value can be set in increments of 0.1 between 0 and 2.5%. The selected setting is shown in the lower display.
  6. Use the **SET** button to save the selected setting and switch to Measurement mode.

### 6.12 Switching Logic

NO mode		NC mode	
<b>One point set mode</b>			
<p>Positive (VS-P10)</p> <p>P-1 Positive P-2*</p>	<p>Vacuum (VS-V)</p> <p>P-1 Vacuum P-2*</p>	<p>Positive/Compound (VS-P10)</p> <p>P-1 Positive P-2*</p>	<p>Vacuum (VS-V)</p> <p>P-1 Vacuum P-2*</p>
<b>Hysteresis mode</b>			
<p>Positive/Compound (VS-P10)</p> <p>L-1 H-1 Positive L-2* H-2*</p>	<p>Vacuum (VS-V)</p> <p>L-1 H-1 Vacuum L-2* H-2*</p>	<p>Positive/Compound (VS-P10)</p> <p>L-1 H-1 Positive L-2* H-2*</p>	<p>Vacuum (VS-V)</p> <p>L-1 H-1 Vacuum L-2* H-2*</p>
<b>Window Comparator mode</b>			
<p>Positive/Compound (VS-P10)</p> <p>L-1 L-2* H-1 H-2* Positive</p>	<p>Vacuum (VS-V)</p> <p>L-1 L-2* H-1 H-2* Vacuum</p>	<p>Positive/Compound (VS-P10)</p> <p>L-1 L-2* H-1 H-2* Positive</p>	<p>Vacuum (VS-V)</p> <p>L-1 L-2* H-1 H-2* Vacuum</p>

**Important notes:**

1. The pressure setting value of P-2, L-2 or H-2 will not be displayed if the output specification is set to one output (1 OUT).
2. If the hysteresis is set to 2 digits or less, the switching output may waver if the input pressure fluctuates near the setpoint.
3. If Window Comparator mode is used, the difference between two setpoints must be greater than the fixed hysteresis. Otherwise, this leads to a malfunction of the switching output.

### 6.13 Voltage Profiles of the Analog Output

Depending on the variant, the analog output supplies a voltage between 1 and 5 V, proportional to the pressure range.

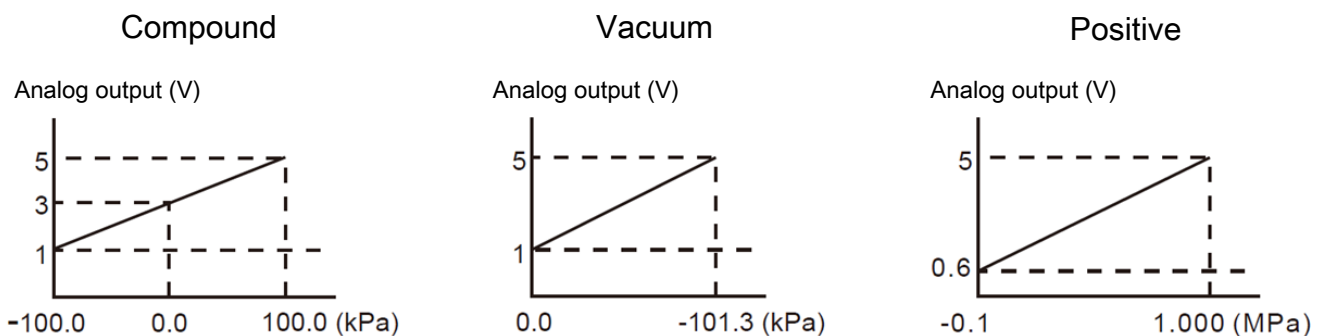

## 7 Troubleshooting

Error type		Error code	Error description	Troubleshooting
Over-load current	OUT1	Er 1	The load current at output 1 is more than 100 mA	<ol style="list-style-type: none"> <li>1. Turn off the power and determine the cause of the overload current, or lower the load to less than 100 mA.</li> <li>2. Restart system.</li> </ol>
	OUT2	Er 2	The load current at output 2 is more than 100 mA	
Residual pressure error		Er 3	During calibration the ambient pressure is over $\pm 3\%$ F.S.	<ul style="list-style-type: none"> <li>▶ Change the input pressure to the ambient pressure and re-calibrate.</li> </ul>
Pressure error		HHH	Exceeding the upper pressure limit.	<ul style="list-style-type: none"> <li>▶ Adjust the pressure within the operating pressure range.</li> </ul>
		LLL	Exceeding the lower pressure limit.	
System error		Er 4	Internal system error	<ul style="list-style-type: none"> <li>▶ Turn off the power and restart.</li> <li>▶ If the error persists, return the product for investigation.</li> </ul>
		Er 5	Internal system error	
		Er 6	Internal data error	
		Er 7	Internal data error	

## 8 Accessories

### 8.1 Accessory Items

Description	Part no.
Horizontal mounting bracket; BEF-WIN 20x43.5x29.5 1.5	10.06.02.00685
Front mounting bracket; BEF-WIN 30x43.5x29.5 1.5	10.06.02.00686
Mounting frame for mounting into switch panel; EINB-RAx8.5x30 VS, installation kit, 3-piece, with protective glass	10.06.02.00427
Connection plug (ready to assemble); ASS S-M12-5 SK	21.04.05.00251

### 8.2 Mounting Accessories

When ordering the holders, the two fastening screws required (M3\*0.5P) are included in the delivery:

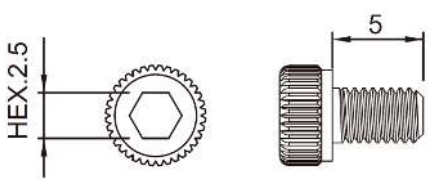

- Hexagon key size 2.5 mm
- The length of the screws must be limited to 5 mm. Do not use standard screws!

#### Holder 10.06.02.00685

##### Mounting

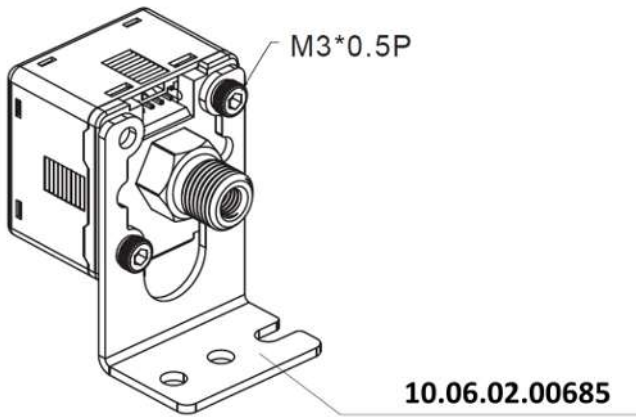

##### Dimensions

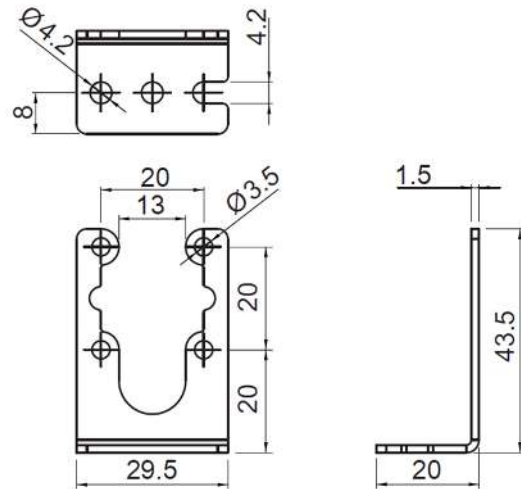

Holder 10.06.02.00686

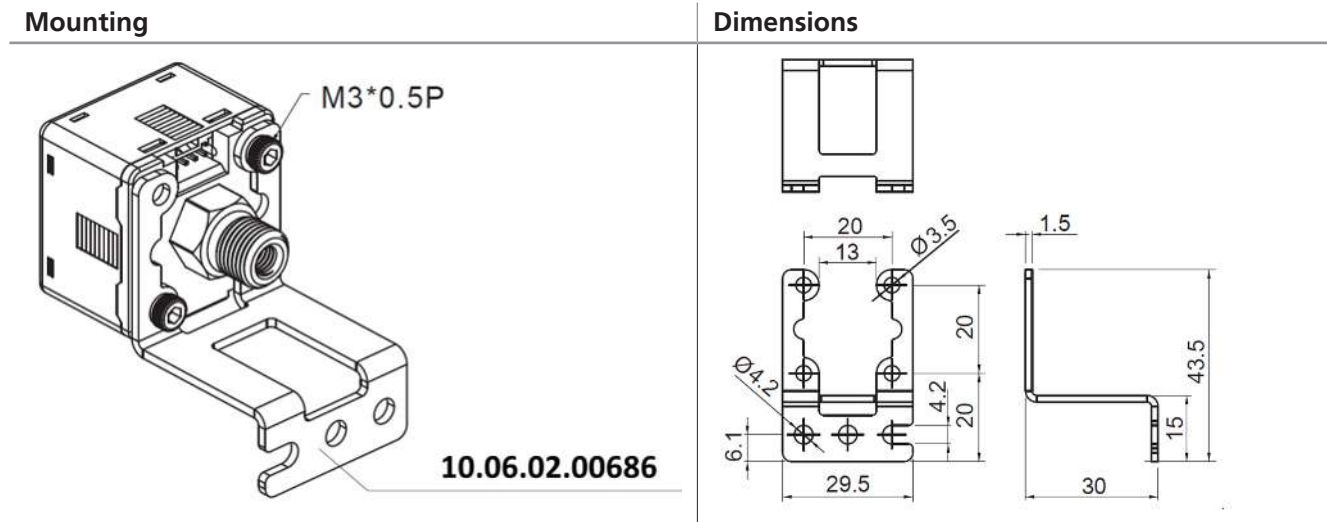

Adapter for mounting into switch panel 10.06.02.00427

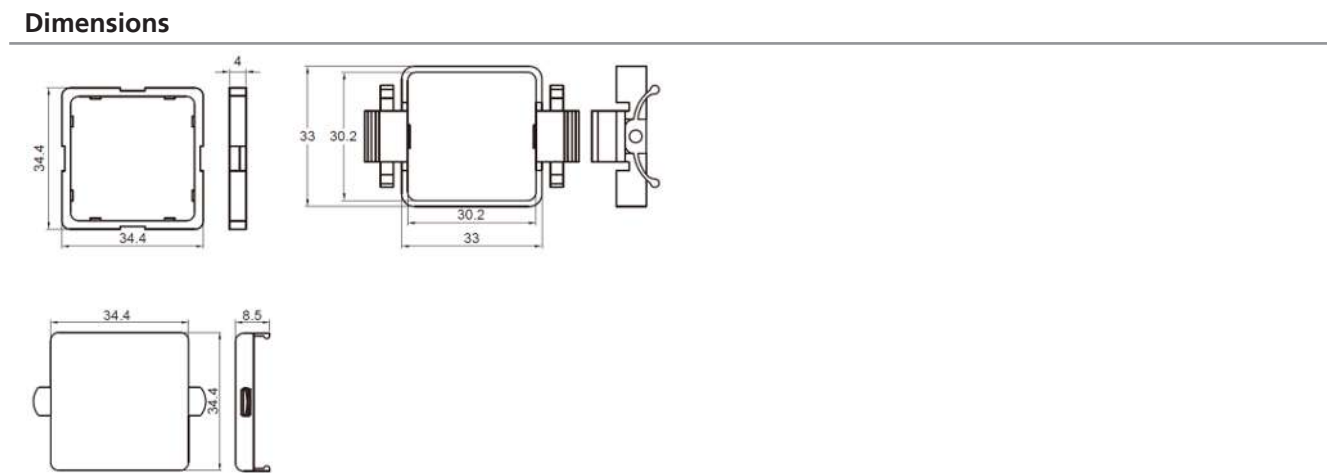
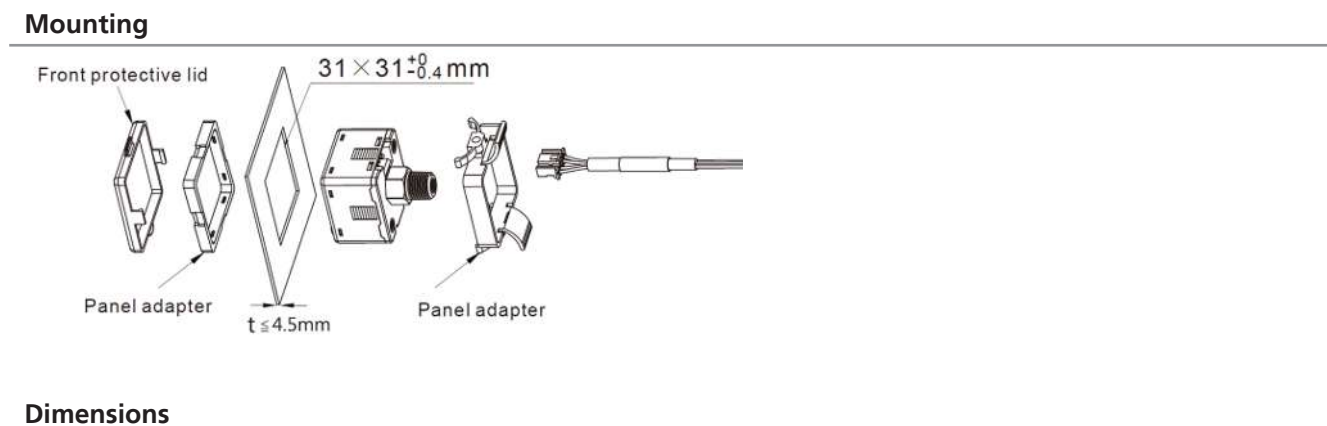

## 9 EC Declaration of Conformity

### *EC Declaration of Conformity*

The manufacturer Schmalz confirms that the Vacuum/pressure switch described in these operating instructions fulfill the following applicable EC directives:

2014/30/EU	Electromagnetic Compatibility
2011/65/EU	Directive on the restriction of the use of certain hazardous substances in electrical and electronic equipment

The following harmonized standards were applied:

EN 61000-6-4	Electromagnetic Compatibility - Emission
EN 61000-6-2	Electromagnetic Compatibility - Immunity
EN 61000-4-2	Electromagnetic Compatibility (EMC) – Part 4-2: Testing and measuring procedures
EN 61000-4-3	Electromagnetic Compatibility (EMC) – Part 4-3: Testing and measuring procedures
EN 61000-4-4	Electromagnetic Compatibility (EMC) – Part 4-4: Testing and measuring procedures
EN 61000-4-6	Electromagnetic Compatibility (EMC) – Part 4-6: Testing and measuring procedures
EN 61000-4-8	Electromagnetic Compatibility (EMC) – Part 4-8: Testing and measuring procedures





## At your side worldwide

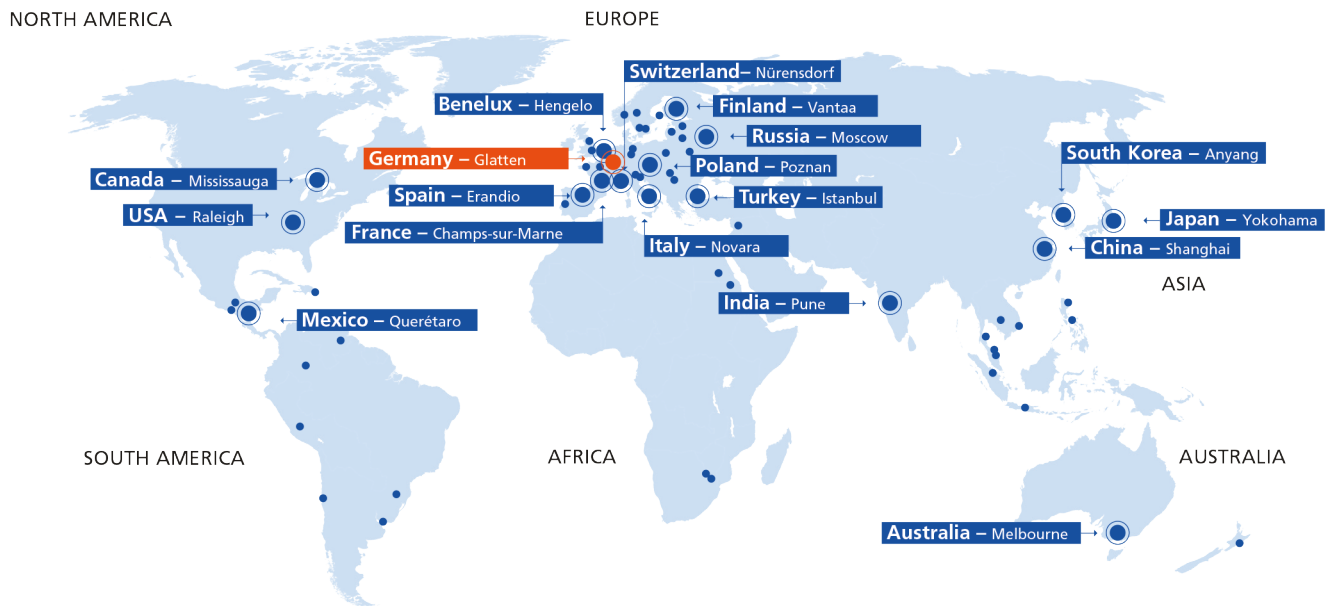

### Headquarters

Schmalz Germany – Glatten

### Subsidiaries

Schmalz Australia – Melbourne  
 Schmalz Benelux – Hengelo (NL)  
 Schmalz Canada – Mississauga  
 Schmalz China – Shanghai  
 Schmalz Finland – Vantaa  
 Schmalz France – Champs-sur-Marne  
 Schmalz India – Pune  
 Schmalz Italy – Novara  
 Schmalz Japan – Yokohama

### Sales Partners

You can find the Schmalz sales partner in your country at:  
[WWW.SCHMALZ.COM/SALESNETWORK](http://WWW.SCHMALZ.COM/SALESNETWORK)

Schmalz Mexico – Querétaro  
 Schmalz Poland – Suchy Las (Poznan)  
 Schmalz Russia – Moscow  
 Schmalz South Korea – Anyang  
 Schmalz Spain – Erandio (Vizcaya)  
 Schmalz Switzerland – Nürens Dorf  
 Schmalz Turkey – Istanbul

## Vacuum Automation

[WWW.SCHMALZ.COM/AUTOMATION](http://WWW.SCHMALZ.COM/AUTOMATION)

## Handling Systems

[WWW.SCHMALZ.COM/HANDLINGSYSTEMS](http://WWW.SCHMALZ.COM/HANDLINGSYSTEMS)

J. Schmalz GmbH  
 Johannes-Schmalz-Str. 1  
 72293 Glatten, Germany  
 T: +49 7443 2403-0  
 schmalz@schmalz.de  
 WWW.SCHMALZ.COM