



VAKUUM-AUTOMATION

## Operating Instructions

Needle gripper SNGi-AE

30.30.01.00576/03 | 05.2019

**Note**

These operating instructions were written in the German language.  
This document should be kept in a safe place for future reference.

The right to make technical changes is reserved. No responsibility is taken for printing errors or other types of errors.

**Publisher**

© J. Schmalz GmbH, 05.2019

This document is protected by copyright. J. Schmalz GmbH retains the rights established thereby. Reproduction of the contents, in full or in part, is only permitted within the limits of the legal provisions of copyright law. Any modifications to or abridgments of the document are prohibited without explicit written agreement from J. Schmalz GmbH.

**Contact**

J. Schmalz GmbH  
Johannes-Schmalz-Straße 1  
D-72293 Glatten

Tel. +49 (0)7443 2403-0  
Fax +49 (0)7443 2403-259  
schmalz@schmalz.de  
www.schmalz.com

Contact information for the Schmalz companies and trading partners, see  
 [www.schmalz.com/vertriebsnetz](http://www.schmalz.com/vertriebsnetz)

# Contents



## Operating Instructions Needle gripper SNGi-AE

1	Safety Notes.....	5
1.1	Classification of Safety notes .....	5
1.2	Warnings .....	6
1.3	Signs.....	6
1.4	General safety instructions.....	7
1.5	Intended use.....	7
1.6	Requirement for the user.....	8
1.7	Emissions .....	8
1.8	Definition of the Danger Zone .....	8
2	Product description .....	9
2.1	Versions.....	9
2.2	Design of the needle gripper .....	10
2.3	General description of functions.....	10
2.4	I/O-Link description .....	11
3	Technical Data .....	12
3.1	Technical Data.....	12
3.1.1	General parameters .....	12
3.1.2	Mechanical parameters .....	13
3.1.3	Dimensions.....	13
3.1.4	Electrical parameters.....	15
3.1.5	Materials used .....	15
4	Transport and mounting .....	16
4.1	Transport .....	16
4.2	Mounting.....	16
4.3	Pneumatic connection .....	17
4.4	Electrical connection .....	18
4.4.1	Direct connection.....	19
4.4.2	Connection via IO-Box .....	19
5	Start of Operations .....	20
5.1	Project planning.....	22
6	Operation .....	23
6.1	IO-Link Data Dictionary (overview).....	24
6.2	Function description .....	26
6.2.1	Needle movement (grabbing / depositing the workpiece) .....	26
6.2.2	Select predefined profiles.....	27
6.2.3	EPC values in the process data .....	28
6.2.4	Travel time.....	30
6.2.5	Blowing-off (assisted deposition).....	30
6.3	Display elements .....	31
6.4	General functions and parameters .....	31
6.4.1	Software version.....	31

6.4.2	Serial number .....	31
6.4.3	Part number .....	31
6.4.4	Zero-point adjustment of the needles (calibration) .....	31
6.4.5	Offset value for the needles .....	32
6.4.6	ECO mode .....	32
6.4.7	Resetting to factory settings .....	32
6.4.8	Counters .....	33
6.4.9	Condition Monitoring warnings .....	33
6.4.10	Error code .....	34
6.4.11	Voltage monitoring .....	34
6.4.12	Energy monitoring (EM) .....	35
6.5	Production setup profiles .....	35
<b>7</b>	<b>Maintenance and Accessories .....</b>	<b>36</b>
7.1	General maintenance .....	36
7.1.1	Exterior dirt .....	36
7.1.2	Interior dirt .....	36
7.1.3	Opening and sealing the maintenance openings .....	37
7.2	Warranty, Spare Parts and Wearing Parts .....	41
7.2.1	Spare and Wearing Parts .....	41
7.3	Troubleshooting .....	42
7.4	Accessories .....	42
7.5	Decommissioning .....	43
<b>8</b>	<b>Explanations of terms .....</b>	<b>44</b>
<b>9</b>	<b>Conformity Declaration .....</b>	<b>45</b>

# 1 Safety Notes

## 1.1 Classification of Safety notes

### Danger

This warning informs the user of a risk that will result in death or serious injury if it is not avoided.

 <b>DANGER</b>	
	<b>Type and source of the Danger</b> Consequence ► Remedial action

### Warning

This warning informs the user of a risk that could result in death or serious injury if it is not avoided.

 <b>WARNING</b>	
	<b>Type and source of the Danger</b> Consequence ► Remedial action

### Caution

This warning informs the user of a risk that could result injury if it is not avoided.

 <b>CAUTION</b>	
	<b>Type and source of the Danger</b> Consequence ► Remedial action

### Important

This warning informs the user of a risk that could result damage to property if it is not avoided.

<b>IMPORTANT</b>	
	<b>Type and source of the Danger</b> Consequence ► Remedial action







### Notice

This symbol is used when important notes and information regarding use of the machine/the system/the device are provided.

	Information on the use
---	------------------------

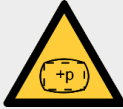





## 1.2 Warnings

Explanation of the warning symbols used in the operating instructions.

Warning symbols	Description	Warning symbols	Description
	General warning symbols		Warning of hearing damage
	Warning of a sharp object		Warning of overpressure
	Warning of environmental damage		Warning of hot surface
	Warning of explosive atmosphere		

## 1.3 Signs

Explanation of the mandatory symbols used in the operating instructions.



Signs	Description	Signs	Description
	Use ear protectors		Use eye protection
	Use hand protection		Wear a mask
	Adhere to the operating instructions		Activate prior to maintenance or repair

## 1.4 General safety instructions

 <b>WARNING</b>	
	<p><b>Ignoring the general safety guidelines</b> Personal injuries / damage to plants / systems</p> <ul style="list-style-type: none"> <li>▶ The operating instructions contain important information on using the gripper. Read the operating instructions thoroughly and keep them for later reference.</li> <li>▶ The system may only be connected and operations started once the operating instructions have been read and understood.</li> <li>▶ Use only the connections, mounting holes and attachment materials that have been provided.</li> <li>▶ Carry out mounting or removal only when the device is in an idle, depressurized state.</li> <li>▶ Only qualified specialist personnel, mechanics and electricians may perform the installation. Qualified specialist personnel are persons who have received technical training and have the knowledge and experience – including knowledge of corresponding regulations – necessary to enable him or her to recognize possible dangers and implement the appropriate safety measures while performing tasks. The same applies to maintenance!</li> <li>▶ General safety regulations, European standards and VDE guidelines must be observed and complied with.</li> <li>▶ Personnel and animals are not permitted to sit or stand in the transport area.</li> <li>▶ No person may sit or stand in the danger zone while the machine or plant is in automatic mode.</li> <li>▶ It is not permitted to make changes to system components.</li> <li>▶ Protect the components from damage of any kind.</li> </ul>

## 1.5 Intended use

The needle gripper is used for handling (gripping and transporting) non-rigid, porous workpieces (e.g. substances, CFRP mats, foams...).

 <b>WARNING</b>	
 	<p><b>Extending needles</b> Injuries caused by pricks, cuts and scratches</p> <ul style="list-style-type: none"> <li>▶ Wear cut resistant gloves</li> </ul>

## 1.6 Requirement for the user



All personnel working with the product must be familiar with basic mechanical and pneumatic principles as well as the appropriate technical terminology.

To ensure safe operation, this work may only be performed by qualified personnel or trained persons working under the supervision of qualified personnel.



*"A qualified employee is defined as an employee who has received technical training and has the knowledge and experience – including knowledge of corresponding regulations – necessary to enable him or her to recognize possible dangers and implement the appropriate safety measures while performing tasks. Qualified personnel must observe the pertinent industry-specific rules and regulations".*

## 1.7 Emissions

The lowering of the workpiece is assisted by a blow-off pulse. The needle gripper emits noise through this blow-off pulse. The sound pressure level is listed in the Technical Data. (see chapter 3.1.2)

 <b>CAUTION</b>	
 	<p><b>Noise pollution due to operation of the gripper with compressed air</b></p> <p>Hearing impairments may occur in the longer term</p> <ul style="list-style-type: none"> <li>▶ Wear ear protectors</li> </ul>

During processing / further processing, the materials to be handled may, in part, be converted to respirable forms.

 <b>CAUTION</b>	
	<p><b>Emission of respirable particles</b></p> <p>Damage to lungs and respiratory tract</p> <ul style="list-style-type: none"> <li>▶ Take the data sheets of the materials to be handled into account</li> <li>▶ Wear respiratory protection</li> </ul>

## 1.8 Definition of the Danger Zone

The danger zone is the area inside, or in the vicinity of working equipment which poses a hazard or potential hazard to the health of persons located within this area.

When lifting the load or transporting it, it is possible that the load could fall, which is why the area directly under the gripper and the load is always considered a danger zone.

A person may not sit or stand under the load for any reason. This applies without exception to both persons and individual body parts (head, hands, arms, legs, etc.).

No person may sit or stand in the designated danger zone.

The working area is to be secured (protective fence or sensors) by the user/operator in such a way that no person can enter the danger zone.



## 2 Product description

### 2.1 Versions

The needle gripper has a specific part designation, e.g. SNGi-AE 10 0.8 V 3 IOL  
 The part designation can be broken down as follows:

Type	Supply energy	No. of needles	Needle diameter	Additional function	Stroke range	Communication
SNGi	AE Operated electrically	10 10 pcs.	0.8 0,8 mm	V Stroke is continuously adjustable	3 3 mm	IOL I/O-Link
			1.2 1,2 mm		10 10 mm	
			20 20 mm			

The needle grippers are classified according to their supply energy as either AP (pneumatically operated) or AE (electrically operated).  
 This documentation only describes the AE version.

## 2.2 Design of the needle gripper

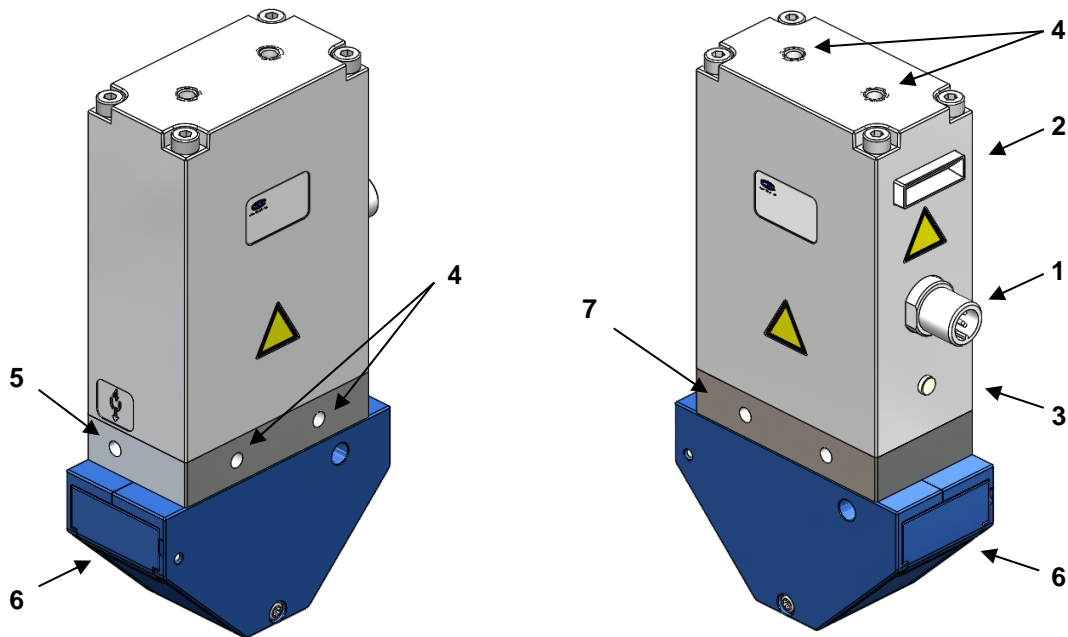

Item	Description
1	Connection plug M12, 5-pin, A-coded
2	Status display (green, yellow, red LED)
3	Power LED (green)
4	M5 mounting thread
5	Compressed air connection M5 "blow-off" (label 4)
6	Maintenance opening cover
7	Heat sink for drive

## 2.3 General description of functions

Needle grippers are designed to handle parts by means of positive locking of the needles with the workpiece. To this end, a distinction is to be made between electrically and pneumatically operated needle grippers. Only the electrical version is considered in these operating instructions.

The needles in an electrical needle gripper are moved by an electrical drive. Communication can occur only via the IO-Link interface.

## 2.4 I/O-Link description

IO-Link is a communications system for linking intelligent sensors and actuators to an automation system and is described in the standard IEC 61131-9 . The standards contains both the electrical connection data as well as a digital communication protocol via which sensors and actuators exchange with data the automation system.

An IO-Link system consists of an IO-Link master and one or more IO-link enabled sensors or actuators. The IO-link master provides the interface to the higher level controller (SPS) and controls the communication between connected IO-Link devices.

An IO-Link master can have one or more IO-Link ports, however only one IO-Link device can be connected to each port. A more detailed description is provided in section 4.4.

IO-Link devices have parameters which are readable or writable via the IO-Link protocol. Parameters can therefore be changed during operation via the higher level controllers.

The sensor and actuator parameters are device specific, therefore parameter information exists in the form of IODD (IO Device Description) for each device. (see section 6.1).

Use of the IO link enables remote parameter setting for the needle gripper, besides this access to the following functions is possible via the IO-Link:

- Condition monitoring (CM):
- Energy monitoring (EM):
- Predictive maintenance [PM]
- ECO – Mode
- Calibration
- Offset value for the needles
- Voltage monitoring
- Production setup profiles
- Diagnosis cushion

For details about these functions see section 6.4

### 3 Technical Data

<b>IMPORTANT</b>	
	<p><b>Non adherence to the performance limits of the gripper</b></p> <p>Malfunction and damage to the gripper and the components attached to it</p> <p>► Only operate the gripper within the specified performance limits</p>

#### 3.1 Technical Data

##### 3.1.1 General parameters

Parameter	Symbol	Limit values			Unit	Note
		min.	typ.	max.		
Working temperature	T <sub>amb</sub>	5	—	50	°C	
Storage temperature	T <sub>Sto</sub>	-10	—	60	°C	
Humidity	H <sub>rel</sub>	10	—	90	% r.h.	Free from condensation
Protection class	-	—	—	IP53		
Duty cycle	-		45		%	
Extension / retraction time per 1 mm stroke *2)	-	0.06	-	0.6	s	
Stroke resolution	-	—	0.1	—	mm	
Repeatability	-	—	±0,05 *1)	—	mm	
Operating pressure	P	2	5	6	bar	
Installation position	Any					
Operating medium	Air or neutral gas, 5 µm filtered, with or without oil, class 3-3-3 compressed air quality acc. to ISO 8573-1					

\*1) at constant temperature

\*2) Extension / retraction time:

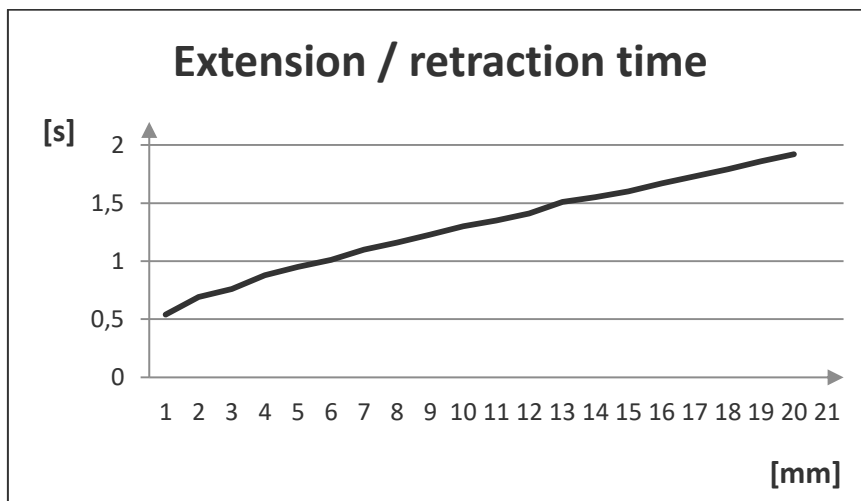

### 3.1.2 Mechanical parameters

Type	No. of needles	Needle diameter	Max. stroke	Needle angle	Total force	Sound level <sup>1</sup> when blowing-off	Weight
	pcs.	mm	mm	°	N	dBA	kg
<b>SNGi-AE 10 0.8 V 3 IOL</b>	10	0.8	3	30	50	78	0.500
<b>SNGi-AE 10 1.2 V 3 IOL</b>	10	1.2	3	30	50	78	0.500
<b>SNGi-AE 10 0.8 V 10 IOL</b>	10	0.8	10	45	50	78	0.515
<b>SNGi-AE 10 1.2 V 10 IOL</b>	10	1.2	10	45	50	78	0.515
<b>SNGi-AE 10 1.2 V 20 IOL</b>	10	1.2	20	45	50	78	0.600

<sup>1</sup> at 5bar and 1m distance

### 3.1.3 Dimensions

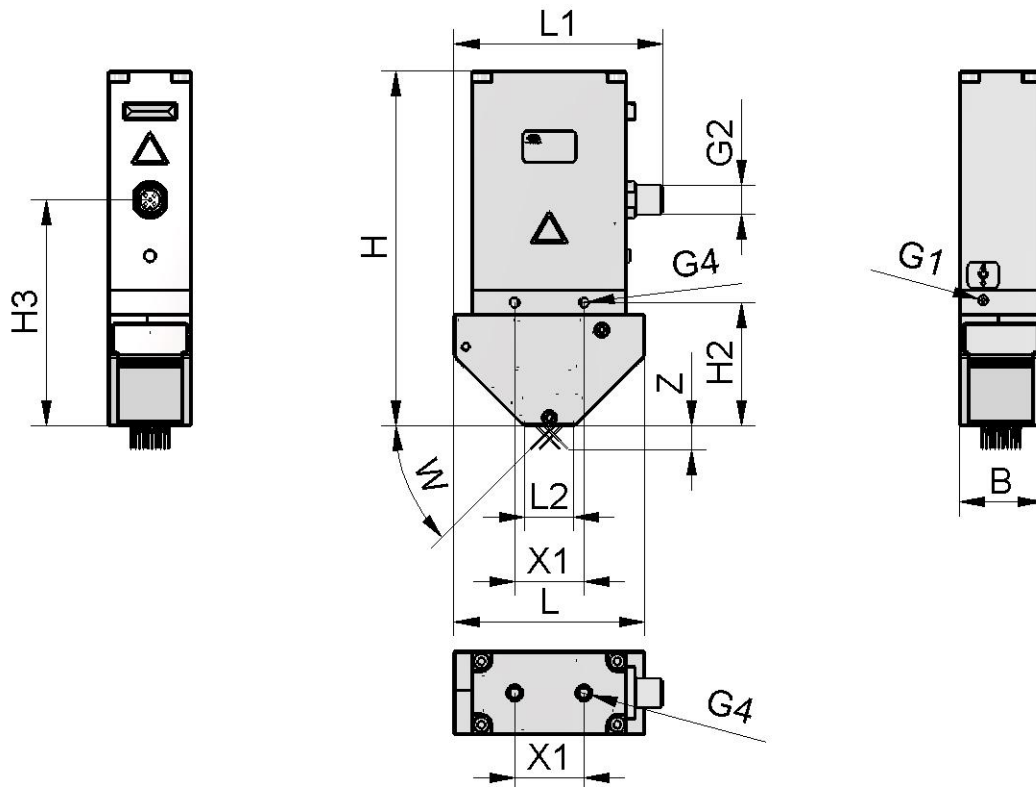

Type	L	B	H	L1	L2	H2	H3
<b>SNGi-AE 10 0.8 V 3 IOL</b>	65	35	140,2	80	28	41,7	86,2
<b>SNGi-AE 10 1.2 V 3 IOL</b>	65	35	140,2	80	28	41,7	86,2
<b>SNGi-AE 10 0.8 V 10 IOL</b>	80	35	152	88	22	52	95
<b>SNGi-AE 10 1.2 V 10 IOL</b>	80	35	152	88	22	52	95
<b>SNGi-AE 10 1.2 V 20 IOL</b>	120	35	178	108	22	78	121

## TECHNICAL DATA

Type	G1	G2	G4	Lg4	X1	Z	W
<b>SNGi-AE 10 0.8 V 3 IOL</b>	M5 (female)	M12 (male)	M5 (female)	7	29	3	30
<b>SNGi-AE 10 1.2 V 3 IOL</b>	M5 (female)	M12 (male)	M5 (female)	7	29	3	30
<b>SNGi-AE 10 0.8 V 10 IOL</b>	M5 (female)	M12 (male)	M5 (female)	7	29	10	45
<b>SNGi-AE 10 1.2 V 10 IOL</b>	M5 (female)	M12 (male)	M5 (female)	7	29	10	45
<b>SNGi-AE 10 1.2 V 20 IOL</b>	M5 (female)	M12 (male)	M5 (female)	7	29	20	45

All specifications are in mm

### 3.1.4 Electrical parameters

Parameter	Symbol	Limit values			Unit	Note
		min.	typ.	max.		
Power supply for sensor	$U_s$	19.2	24	26.4	V <sub>DC</sub>	PELV <sup>1)</sup>
Power supply for actuator	$U_A$	19.2	24	26.4	V <sub>DC</sub>	PELV <sup>1)</sup>
Rated current for sensor	$I_s$	—	—	80	mA	
Rated current for actuator	$I_A$	—	550	900 <sup>2)</sup>	mA	

1) The power supply must correspond to the regulations in accordance with EN60204 (protected extra-low voltage).  
The power supply and IO-Link pin are protected against reverse polarity.

2) The maximum power is only measured in boost mode.

### 3.1.5 Materials used

Component	Material
Main body	PA6-GF10GK20
Inner components	Aluminum alloy, anodized aluminum alloy, brass, red bronze, stainless-steel, PA, PU, POM steel
Sealings	NBR
Lubrication	Silicone-free
Screws	Galvanized steel

## 4 Transport and mounting

### 4.1 Transport

The needle gripper comes in cardboard packaging. In order to ensure safe transport, the gripper must be transported in this packaging for all subsequent transports. Transport of the needle gripper is only permitted when the needles are retracted.

! <b>WARNING</b>	
	<p><b>Extending needles</b> Injuries caused by pricks, cuts and scratches</p> <ul style="list-style-type: none"> <li>▶ Wear cut resistant gloves</li> <li>▶ Make sure that the needles have been retracted</li> </ul>

### 4.2 Mounting

There are two M5 tapped holes on the front, rear and top respectively for mounting the needle gripper (see the table below for tightening torque). The appropriate holder for integrating the needle gripper into a tooling system is available from Schmalz (see accessories). Only the mounting threads provided are to be used for mounting.

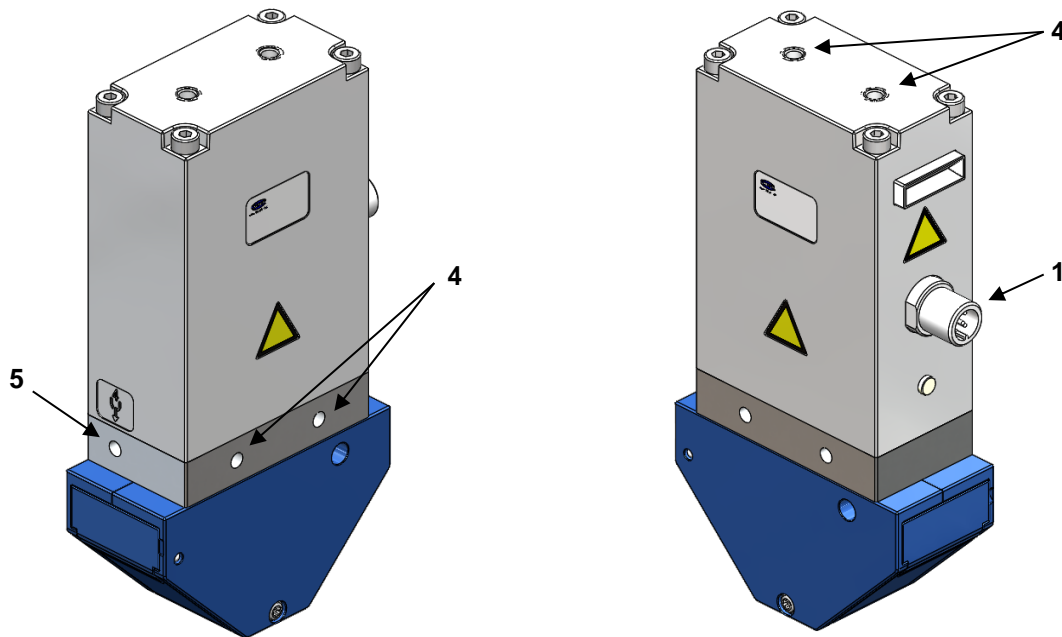

Item	Description	Maximum torque
1	Connection plug M12, 5-pin, A-coded	Hand-tight
4	M5 mounting thread	2 Nm
5	Compressed air connection M5 "blow-off" (label 4)	4 Nm



Please note the connection symbols and descriptions on the gripper.



<b>IMPORTANT</b>	
	<p>Faulty mountings and connections Damage to the gripper</p> <ul style="list-style-type: none"> <li>▶ Use only the connections, mounting holes and attachment materials that have been provided</li> <li>▶ Observe the thread length of the connection thread, c.f. <b>Fehler!</b></li> <li>▶ Comply with the specified tightening torque</li> </ul>





Use washers when mounting.

The needle gripper may be installed in any position.

### 4.3 Pneumatic connection

Prior to coupling or uncoupling of the needle gripper, the line to the compressed air supply is to be depressurized. Make sure prior to pressurizing the needle gripper with operating pressure that the plug-in screw unions of the compressed air connections are safely screwed together, the supply lines are properly aligned in the plug-in screw union and that the area around the outlet openings of the needle is free of any objects.

 <b>CAUTION</b>	
	<p><b>Installation of the gripper under compressed air</b> Personal injury and/or damage to property</p> <ul style="list-style-type: none"> <li>▶ Depressurize the gripper</li> <li>▶ Screw and / or align the supply lines safely in plug-in screw unions and connections</li> <li>▶ Secure the machine / plant / system so that it cannot be switched on again</li> </ul>



High quality compressed air prolongs the service life of the needle gripper. Use only well maintained compressed air (air or neutral gas according to EN 983, filtered 5 µm, oiled or unoled). See also chapter 1.5

The workpiece is used in connection with compressed air when using the blow-off function.

Lay hose and pipe lines as short as is possible and without bends or crimps.

## 4.4 Electrical connection

The electrical connection is established via a five-pin, A-coded M12 plug with an IO-Link class B pin assignment. The needle gripper is supplied with sensor and actuator voltage via this plug, the IO-Link signal is also connected (Pin 4).

The sensor power supply and the IO-Link signal are electrically isolated from the actuator voltage. The maximum line length between the IO-Link master and the needle gripper is 20 m.

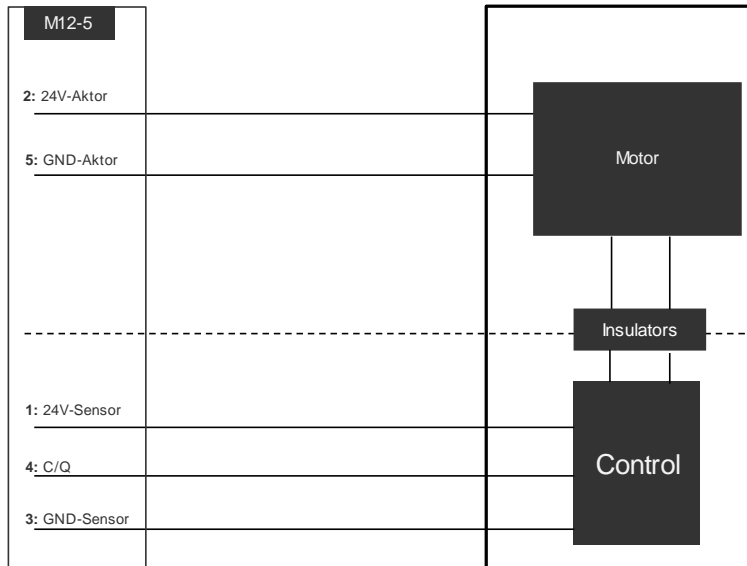

Plug	Pin	Wire color <sup>1)</sup>	Symbol	Function
	1	Brown	$U_s$	Power supply for sensor
	2	White	$U_A$	Power supply for actuator
	3	Blue	$Gnd_s$	Sensor ground
	4	Black	C/Q	IO-Link
	5	Gray	$Gnd_A$	Actuator ground

1) for use with Schmalz connection line part no. 21.04.05.00080

**DANGER**

**The output signals can change when the power supply is switched on or the M12 connector is plugged in.**

Danger to life and limb

- ▶ The electrical connection must only be carried out by individuals who are able to assess the impact of signal changes on the overall machine / facility / system.

**CAUTION**

**Connection of gripper when voltage and / or compressed air is applied**

Personal injury and/or damage to property

- ▶ Disconnect the gripper completely from the supply lines
- ▶ Secure the machine / plant / system so that it cannot be switched on again

<b>ATTENTION</b>	
	<p><b>Inappropriate voltage supply</b> Destruction of gripper</p> <ul style="list-style-type: none"> <li>▶ Only operate gripper using power supply units with protected extra-low voltage (PELV)</li> <li>▶ The system must incorporate safe electrical cut-off of the power supply in compliance with EN60204</li> <li>▶ Do not connect or disconnect the plug connectors when voltage is applied</li> </ul>

#### 4.4.1 Direct connection

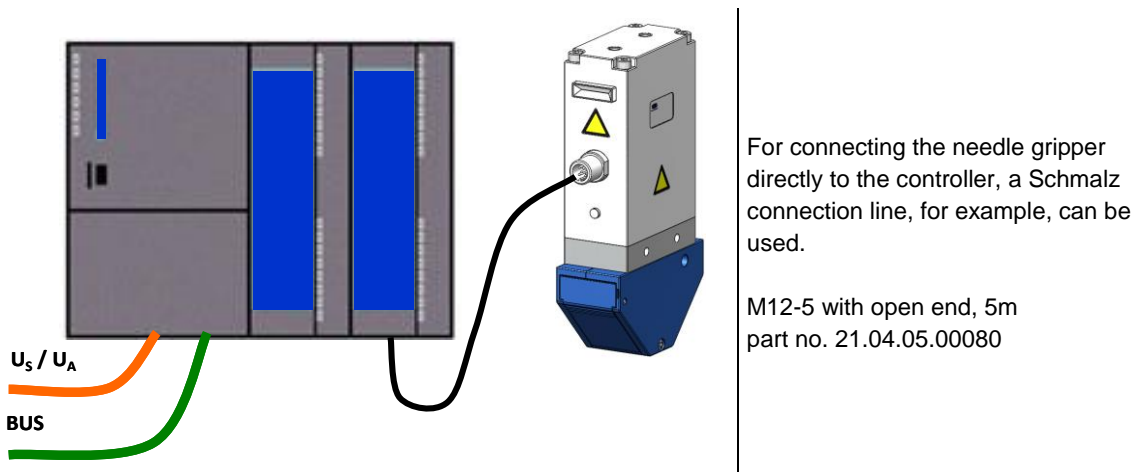

#### 4.4.2 Connection via IO-Box

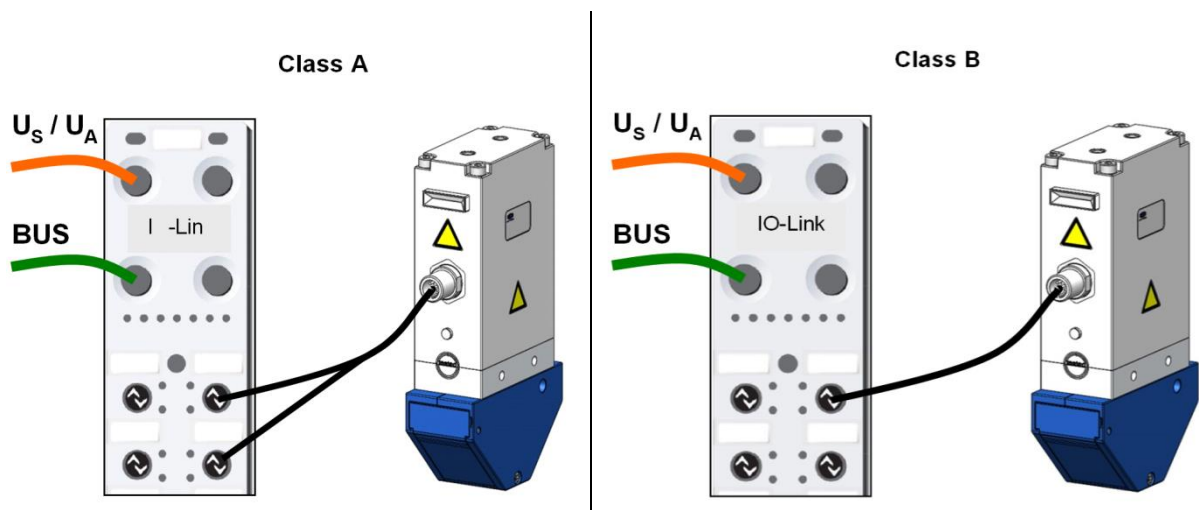











For connecting the needle gripper to IO-Boxes, Schmalz connection lines and Schmalz connection distributors, for example, can be used.

M12-5 on 2xM12, 1m      part no. 10.02.02.04336

M12-5 on M12-5, 1m      part no. 21.04.05.00158  
or  
M12-5 on M12-5, 2m      part no. 21.04.05.00211

## 5 Start of Operations

 <b>DANGER</b>	
	<p><b>Risk of fire and explosion.</b> Death or very serious injury</p> <ul style="list-style-type: none"> <li>▶ The gripper must not be used in environments where there is a risk of explosion.</li> </ul>
 <b>CAUTION</b>	
 	<p><b>Pressure can cause closed devices to explode</b> Personal injury and/or damage to property</p> <ul style="list-style-type: none"> <li>▶ Wear protective glasses</li> </ul>
 <b>CAUTION</b>	
 	<p><b>Hot drive heat sink</b> This presents a burn hazard</p> <ul style="list-style-type: none"> <li>▶ Wear gloves</li> </ul>
 <b>WARNING</b>	
 	<p><b>Extending needles</b> Injuries caused by pricks, cuts and scratches</p> <ul style="list-style-type: none"> <li>▶ Wear cut resistant gloves</li> </ul>

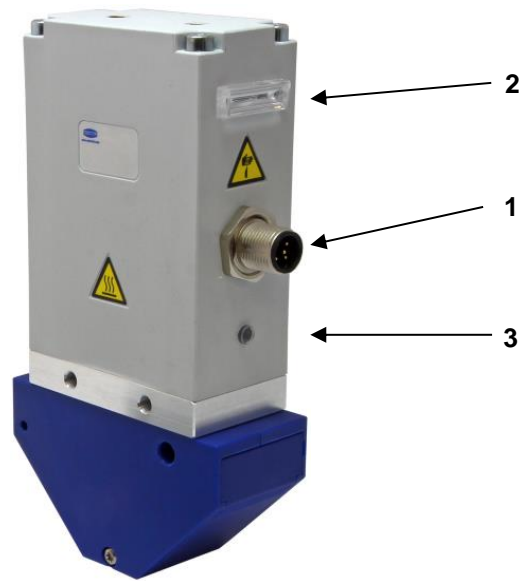

Item	Description
1	Connection plug M12, 5-pin, A-coded
2	Status display (green, yellow, red LED) see section 6.3
3	Power LED (green) see section. 6.3

Start of operations is not permitted until mounting has been completed successfully (see chapter 0). For safety reasons, the needle gripper is supplied with a needle stroke of zero millimeter.

<b>IMPORTANT</b>	
	<p><b>Inserting the needle into hard surfaces</b></p> <p>Damage to the needles</p> <ul style="list-style-type: none"> <li>▶ Adjust the needle gripper for soft surfaces. The material thickness must be greater than the maximum stroke of the gripper.</li> </ul>

Before starting operations with the needle gripper, the sensor power supply and the actuator power supply as well as the IO-Link communication line must be connected.



Following each sensor voltage interruption, return the needle to the home position!

The needles-in-home-position bit is then set.

The communication wire for the IO-Link (Pin 4) must always be connected with an IO-Link master port (point-to-point connection). Several C/Q wires cannot be connected to just a single IO-Link master port.

With the IO-Link all modifiable parameters can be read directly via the higher-level controller, modified and written back to the gripper, see separate "Data dictionary"

The needle gripper supports both the IO-Link Standard 1.1 as well as Standard 1.0 with four bytes of input data and two bytes of output data.

The exchange of process data between the IO-Link master and needle gripper is cyclical. Parameter data (acyclical data) is exchanged by the user program in the controller.

## 5.1 Project planning

An IODD file can be used for integrating the needle gripper into a controller or a PC-Tool. This is available for download in two versions at [www.schmalz.com](http://www.schmalz.com):

- IODD in accordance with the 1.1 Standard, for use with IO-Link masters that use Standard V1.1.
- IODD in accordance with the 1.0 Standard, for use with IO-Link masters that use Standard V1.0 (legacy mode).

The needle gripper can be read out and parameterized online.





The parameters available for the needle gripper can be found in the separate "Data dictionary".

The parameters are divided into cyclical and acyclical parameters.

The acyclical parameters are divided in turn into

- Commands
- Identification parameters
- Initial Setup
- Calibration
- Observation
- Diagnosis

## 6 Operation

<b>! DANGER</b>	
	<p><b>Risk of fire and explosion.</b> Death or very serious injury</p> <ul style="list-style-type: none"> <li>▶ The gripper must not be used in environments where there is a risk of explosion.</li> </ul>
<b>! CAUTION</b>	
 	<p><b>Pressure can cause closed devices to explode</b> Personal injury and/or damage to property</p> <ul style="list-style-type: none"> <li>▶ Wear protective glasses</li> </ul>
<b>! CAUTION</b>	
 	<p><b>Hot drive heat sink</b> This presents a burn hazard</p> <ul style="list-style-type: none"> <li>▶ Wear gloves</li> </ul>
<b>! WARNING</b>	
 	<p><b>Extending needles</b> Injuries caused by pricks, cuts and scratches</p> <ul style="list-style-type: none"> <li>▶ Wear cut resistant gloves</li> </ul>
<b>IMPORTANT</b>	
	<p><b>Non adherence to the performance limits of the gripper</b> Malfunctions and damage to the gripper and the components attached to it</p> <ul style="list-style-type: none"> <li>▶ Only operate the gripper within the specified performance limits</li> </ul>

## 6.1 IO-Link Data Dictionary (overview)

Only an overview of the Data Dictionary is provided here. A full version of the Data Dictionary is available for download under the relevant items at [www.schmalz.com](http://www.schmalz.com).

The default settings for IO-Link communication in both modes (IO-Link V1.1 and legacy mode) are as follows:

Parameter	IO-Link 1.1	IO-Link 1.0 ( legacy mode)
SIO-Mode	No	No
Baud rate	38.4 kBd	38.4 kBd
Minimal cycle time	3.3 ms	16.0 ms
Process data input	4 bytes	4 bytes
Process data output	2 bytes	2 bytes

After communication with an IO-Link master is established, the following process data is available:

Process Data Out (PD Out)	Name	Bit	Access	Note
PD Out Byte 0	Go to Position	0	wo	Needles move to the position entered in "PD Out Byte 1".
	Home-Position	1	wo	Needles are retracted to the 0 – Position
	Move enable	2	wo	Enable bit for needle movement
	Calibration	3	wo	Function for zeroing needles. When this bit is set, the needle gripper moves to the home position. The "move enable bit" must also be set for this to occur.
	EPC-SEL0	4	wo	These two bits decide which data should be displayed in the last three bytes (PD In Byte 1 & 2 & 3) of the process data. Both bits must be set to zero between one decision and the next. The EPC-ACK bit in PD In Byte 0 is provided to confirm that something other than the standard data has been selected.
	EPC-SEL1	5	wo	
	Pset0	6	wo	These two bits select the relevant profile starting from Index 0X00CA. In each profile the travel path and speed can be determined. If the IO-Link master used only supports Version 1.0, then these profiles must be set on a PC using an IO-Link configuration tool.
Pset1	7	wo		
PD Out Byte 1	Position in 0.1mm	7...0	wo	1 = 0.1mm stroke to 30 = 3mm stroke or to 100 = 10mm stroke or to 200 = 20mm stroke



Process Data In	Name	Bit	Access	Note
PD In Byte 0	Needles in Position	0	ro	Needles have reached the target position
	Needles in home position	1	ro	Needles are fully retracted (i.e. in home position)
	Needles moving	2	ro	This bit is set while the needles are moving
	Calibration	3	ro	This bit is set while the needles are moving
	EPC-ACK	4	ro	This bit is set if standard information is displayed in the final two bytes (PD In Byte 1 & 2) of the process data.
	Device status – green	5	ro	The needle gripper is ready
	Device status – yellow	6	ro	At least one warning is present. Please read Index 0x0092.
	Device status – red	7	ro	The needle gripper is out of operation. At least one error message is present. Please read Index 0x0082.
PD In Byte 1	Condition monitoring [CM]	7...0	ro	Dependent on the value selected by the EPC-Sel bits see EPC values in section 6.2.3
PD In Byte 2	EPC Word low byte	7...0	ro	Dependent on the value selected by the EPC-Sel bits: see EPC values in section 6.2.3
PD In Byte 3	EPC Word high byte	7...0	ro	

## 6.2 Function description

### 6.2.1 Needle movement (grabbing / depositing the workpiece)

The target position of the needles is sent to the gripper via the O-Link interface. The needles are extended or retracted at the angle stated by the drive (dependent on model).

The actual position can be read continuously. In the event of unplanned deviations, warning and any error messages are sent to the SPS or the IO-Link master.

The needles are moved according to the following process flow-diagram:

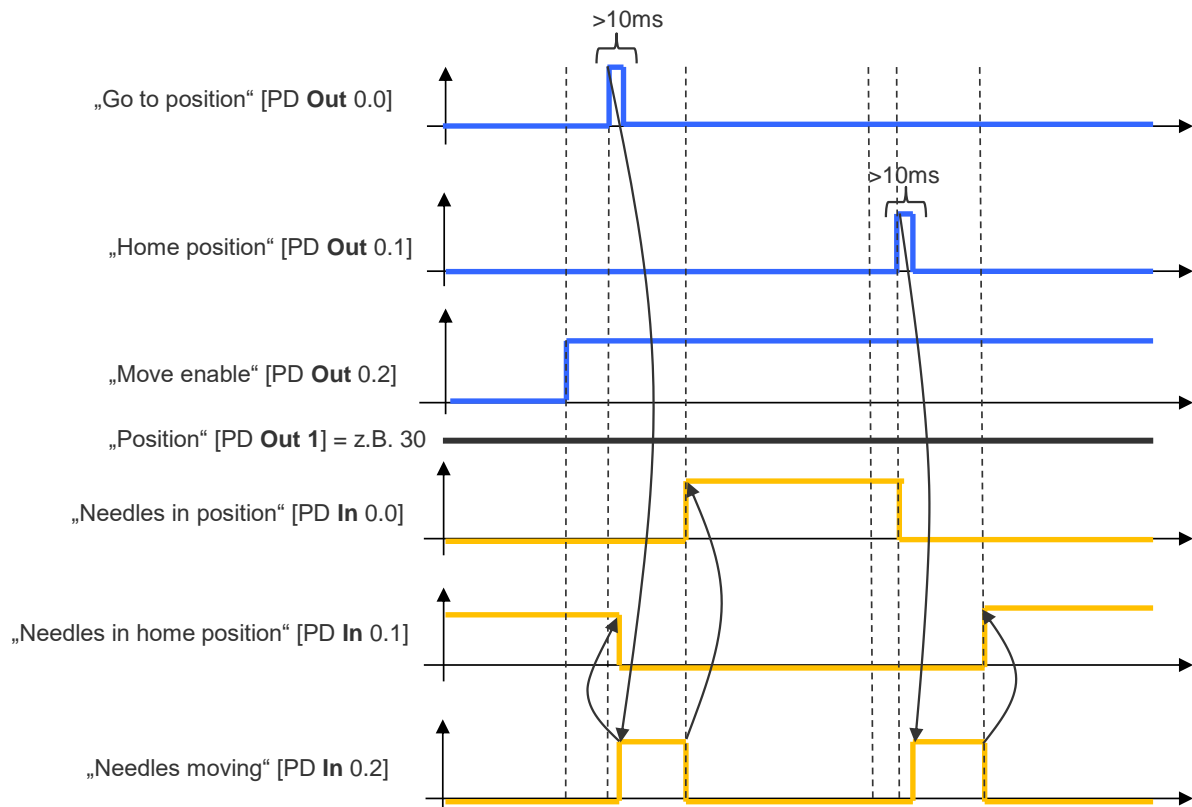

Following each sensor voltage interruption, return the needle to the home position!

The needles-in-home-position bit is then set.

The „Go to position“ bit must be reset to „0“ following each needle movement.

## 6.2.2 Select predefined profiles

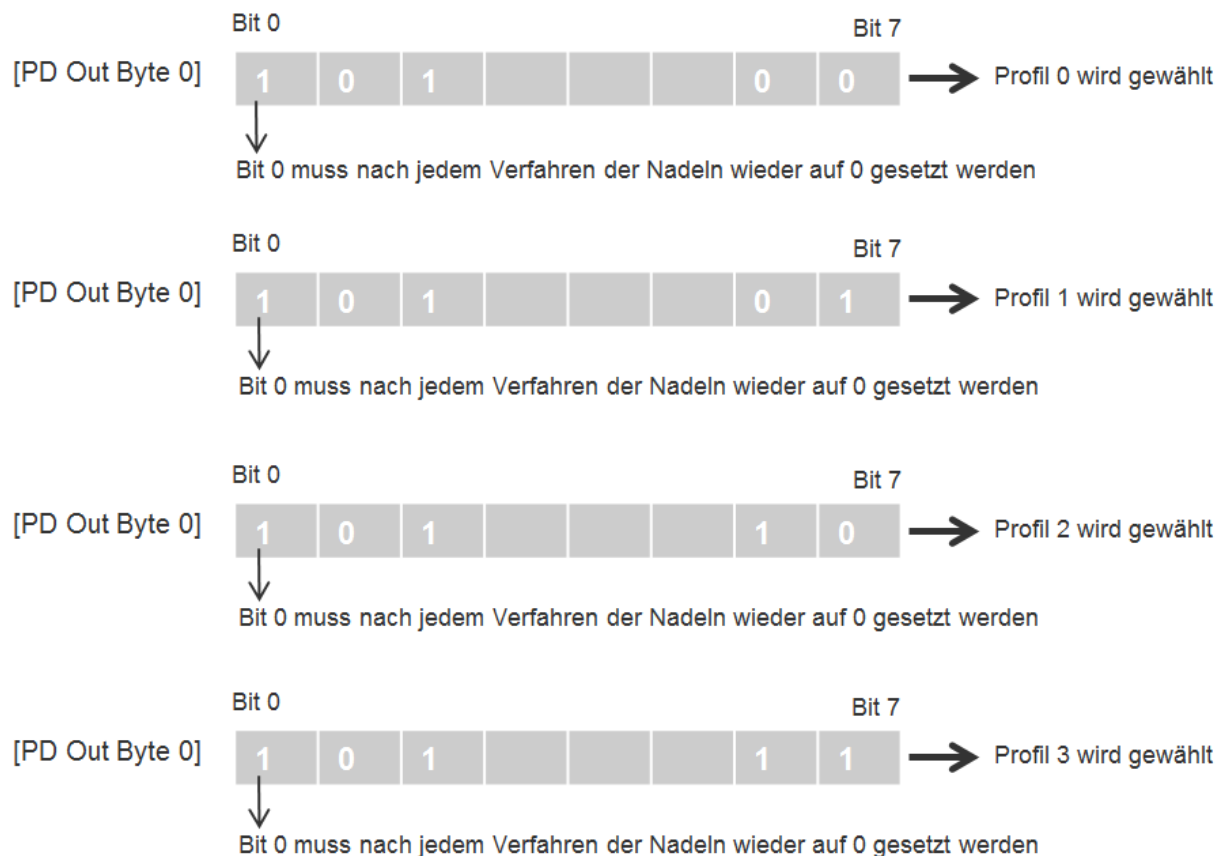

In order to ensure that the ACTUAL position of the needles selected corresponds with the TARGET position selected, the lowest bit of byte 0 in the "Process Data in" area can be read during or after the travel time. If the target position has been reached, this bit is set to 0.

For reading out the current position of the needles, the value in the parameter can be read (e.g. 10 corresponds to 1mm, 200 corresponds to 20mm).



The needles do not move, if the "Go to position Bit" in Byte 0 is not set

If the retraction force of the needles is not sufficient to retract the needles from the gripped material, boost mode is activated. This then increases the retraction force of the needles. The relevant warning is sent to the SPS or the IO-Link master.



Boost mode results in increased heating of the needle gripper so for this reason it is automatically deactivated again after the cycle.

### 6.2.3 EPC values in the process data

To quickly and conveniently capture the most important results from the condition monitoring [CM], energy monitoring and predictive maintenance functions, these are also provided via the process input data of the device. The top 3 bytes of the process output data are also configured as a multifunctional data range, consisting of an 8 bit value ("EPC Value 1) and a 16 Bit value ("EPC Value 2").

The current content of this data supplied by the needle gripper can be changed via the process output data using the 2 bits "EPC-Select". The four potential ways this data is used is listed in the following table:

	PD Out Byte 0 (bit 4 and bit 5)	PD In Bytes 1, 2 and 3		PD In Byte 0 (Bit 4)
	EPC-Select	EPC-Value 1 (8 bit)	EPC-Value 2 (16 bit)	EPC-ACK
Online	00	Needle movement speed %	Current position of the needles 0.1mm (Parameter Index 0x0040)	0
[CM]	01	CM warnings (encoding see parameter Index 0x0092)	Temperature [Unit °C]	1
[PM]	10	[PM]	Travel time (units s)	1
[EM]	11	Power supply (Parameter Index 0x0042) (units 0.1 V)	Energy used in previous cycle (Parameter Index 0x0091)	1

The switching is made with a certain delay depending on the structure of the automation system. However, in order to be able to securely read the different pairs of values through a controller program, the EPC-ACK bit (PD In Byte 0 bit 4) is provided in the process input data. The bit always accepts the values shown in the table.

In order to read out all EPC values, the procedure illustrated in the following diagram is recommended: Always start with EPC-Select = "00" and create the selection for the next value pair required, e.g. EPC-Select = "01".

Wait for the EPC-ACK bit to change from 0 to 1. It is then known that the values transmitted match with the selection created, they can be assumed by the controller.

Now you switch back to the EPC-Select = "00", in order to be able to receive the EPC-ACK flank from 0 to 1 again for monitoring the next data.

**Procedure for monitoring all EPC values via process data.**

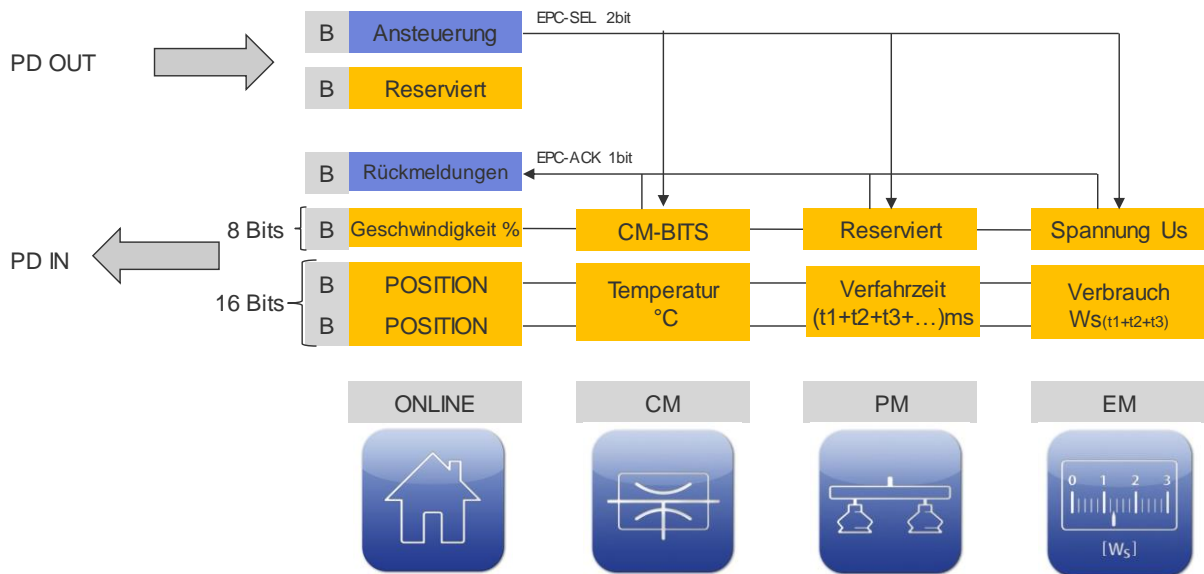
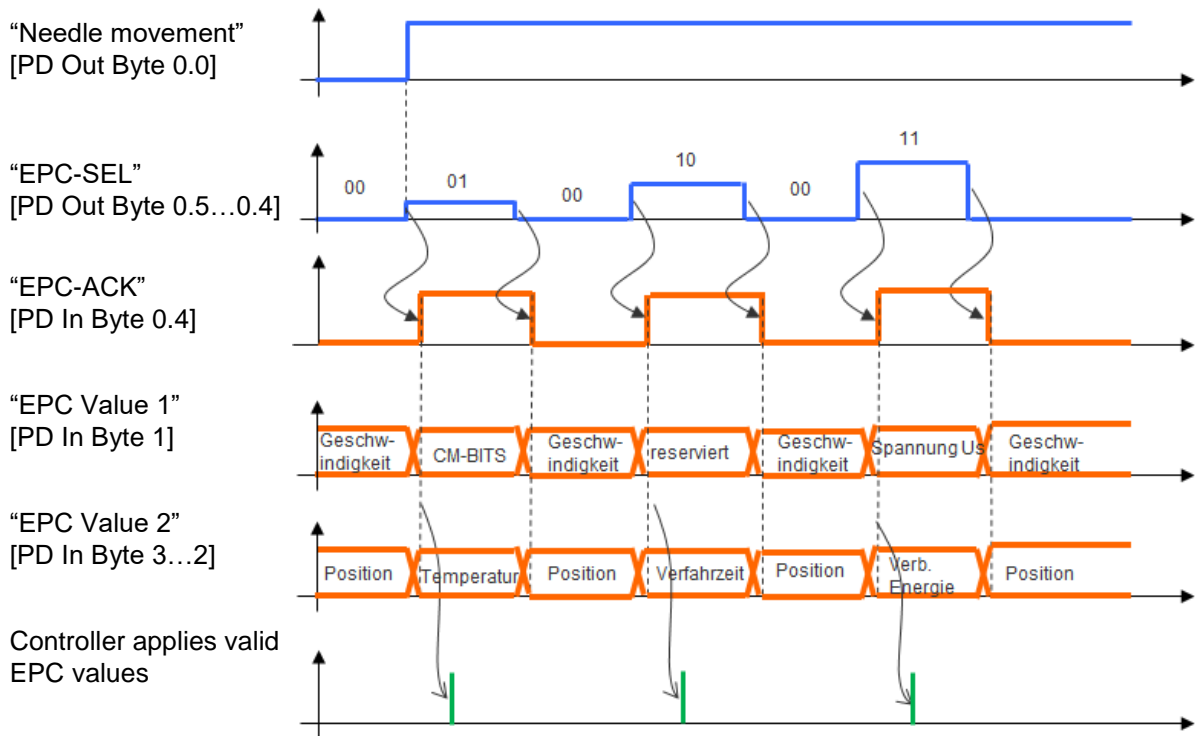

### 6.2.4 Travel time

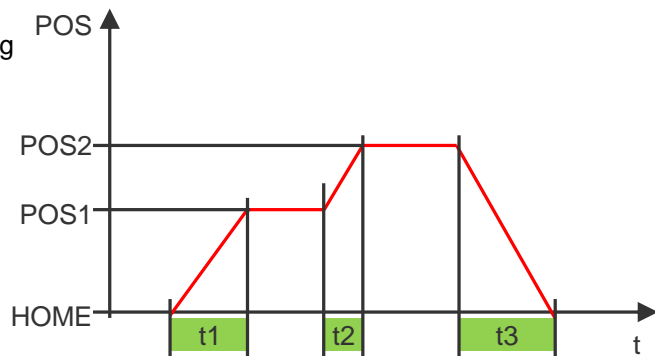

The total travel time of the needles following each movement is provided among the process data.  
The total travel time is retained until the start of the next cycle.



### 6.2.5 Blowing-off (assisted deposition)

In order to support the depositing of adhesive workpieces for example, there is the option of generating a flow of compressed air through the needle outlet openings.  
To this end, input 4 on the gripper is energized with compressed air.

! CAUTION	
	<p><b>Heavy exhaust air flow at the air outlet openings</b></p> <p>Damage to the eyes</p> <ul style="list-style-type: none"> <li>▶ Do not look into the exhaust air flow</li> <li>▶ Wear protective glasses</li> </ul>







! CAUTION	
 	<p><b>Noise pollution due to operation of the gripper with compressed air</b></p> <p>Hearing impairments may occur in the longer term</p> <ul style="list-style-type: none"> <li>▶ Wear ear protectors</li> </ul>

The gripper must only be used with well maintained compressed air (air or neutral gas according to EN 983, filtered 5 µm, oiled or unoled).

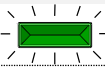
	<p>The workpiece is used in connection with compressed air when using the blow-off function.</p>
---	--

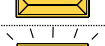
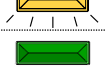
## 6.3 Display elements

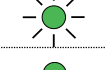
The mode is displayed for the operator via the LEDs

	<b>Status display</b>		
			Green flashing = needles moving but "target position" not yet reached
			Green = "current position" of needles is same as "target position"
	2		Red = maintenance necessary (see. error code)
			Yellow = maintenance advance warning
			Yellow flashing = warning occurred, but needles still moving
			Green = system ok
<b>Power-LED</b>			
3		Power-LED Green flashing = there is voltage at the sensor	
		Green = there is voltage in the sensor and the actuator	

## 6.4 General functions and parameters

Only some of the needle gripper functions and parameters are described in this section. In order to learn about all parameters, please read the data dictionary under [www.schmalz.com](http://www.schmalz.com)

### 6.4.1 Software version

The software version indicates the software currently running on the internal controller. This is available in the identification parameter 0x0017.

### 6.4.2 Serial number

The serial number indicates the production period of the needle gripper. This is available in the identification parameter 0x0015.

### 6.4.3 Part number

The part number both appears on the label on the needle gripper, and is stored electronically. This is available in the identification parameter 0x0014

### 6.4.4 Zero-point adjustment of the needles (calibration)

The calibration function is carried out for the zero-point adjustment of the needles. This is available as a bit in the process data as an ISDU parameter. If bit 3 is set in PD Out, or the value "1" is set in the Index 0x0078, a separate 'needle to home position' is carried out, which contains the calibration of the needle positions.

### 6.4.5 Offset value for the needles

In order to offset potential tolerances when using several grippers in one system, the offset value of the needles (between end-stop and home-position) can be changed. This is in the parameter index 0x0050 and is permitted in a range of 0.0 to 0.4mm. The default value is 0.1mm.

### 6.4.6 ECO mode

To save energy and increase the service life of the needle gripper, it is possible to reduce the power consumption of the system through the Eco-Mode. The activation and deactivation of the ECO mode occurs via Index 76 in the ISDU parameters.



Activating the ECO mode reduces the punching force of the needles by 20%.



If by activating ECO mode the error "overload" occurs, then ECO mode must be deactivated, otherwise ECO mode is always recommended.

### 6.4.7 Resetting to factory settings

This function restores the needle gripper configurations of the initial setup and the settings of the active production setup profile to the factory settings. This function does not affect counter readings, the zero-point adjustment of the needle position or the "Application Specific Tag" IO-Link parameter.



The function for restoring the factory settings does not affect the currently inactive production setup profiles.



## 6.4.8 Counters

The needle gripper has two counters, one counter can be deleted and the other cannot.

Counter 1 and 2 increases with each valid “Needle out or retract ” command, meaning that it counts all gripping cycles during the needle gripper’s service life. Counter 3 and 4 increase each time a warning or an error occurs in the needle gripper.

Function	Description	Parameter-Index
Counter 1	Counter for gripping cycles (deletable) (Command "needle in and extend" or “needle move”)	0x008C
Counter 2	Counter for gripping cycles (not deletable) (Command "needle in and extend" or “needle move”)	0x008E
Counter 3	Counter for number of errors and warnings (deletable)	0x008F
Counter 4	Counter for number of errors and warnings (not deletable)	0x0091

## 6.4.9 Condition Monitoring warnings

Condition monitoring to increase system availability

If a warning occurs, this will be sent via IO-Link parameters in the form of a warning code. The functionality of the needle gripper is retained in the case of a warning.

You can find a list of possible warnings and the corresponding codes in the following table:

Index 0x0092 Bit	Description of warning	Possible measures
0	Booster mode was not activated due to an overload In booster mode the needles move with maximum force into the home position, this increases the heat of the needle gripper, booster mode is therefore deactivated automatically upon the next return to home position.	If this only occurs once or twice, then this is still acceptable, otherwise the user should check the travel path of the needles to see whether an excessively hard material is causing an obstruction.
1	Reserved	
2	Reserved	
3	Reserved	
4	Reserved	
5	Actuator power supply is slightly outside the permitted range (in the yellow range)	Check the power supply and adjust if required.
6	Sensor power supply is slightly outside the permitted range (in the yellow range)	Check the power supply and adjust if required.
7	Overheating	Check the travel path of the needles to see whether an excessively hard material is causing an obstruction. Check the ambient temperature

### 6.4.10 Error code

If an error occurs, this will be sent via IO-Link parameters in the form of a warning code. The functionality of the needle gripper is not guaranteed in the event of an error. The needle gripper drive is stopped. You can find a list of possible errors and the corresponding codes in the following table:

<b>Error-Code 0x0082</b>	<b>Description</b>	<b>Possible measures</b>
01	Electronic error - EEPROM	Restart the entire power supply to the needle gripper.
02	Electronics error – internal communication	Restart the entire power supply to the needle gripper.
03	Calibration is necessary/ overload present	Carry out the calibration function as shown in section 6.4.4
05	Actuator undervoltage supply	Check the actuator voltage supply and switch it on if necessary
07	Sensor undervoltage supply	Check the sensor voltage supply and switch it on if required.
12	Short circuit pin 4 (IO-Link)	This error can be read out in the error counter after the next successful communication
15	Actuator power supply is too high	Check the actuator power supply and reduce if required.
17	Sensor power supply is too high	Check the sensor power supply and reduce if required.
18	Punching force exceeds the max. punching force permitted	Check needles for wear.
19	Overheating	Check the travel path of the needles to see whether an excessively hard material is causing an obstruction. Check the ambient temperature Restart the entire power supply to the needle gripper.

### 6.4.11 Voltage monitoring

The needle gripper has two internal voltage monitors for actuator and sensor voltages.

#### Actuator voltage

If the actuator voltage supply falls below the permitted threshold, the needle gripper sends error message 05 via IO-Link and stops any movement of the needles. The status display turns red and the green power-LED also begins to flash.

In addition to this, an actuator voltage supply which is too high is also detected, error message 15 is then sent via IO-Link and stops any movement of the needles, see 6.4.10

#### Sensor voltage

If the sensor voltage supply falls below the permitted threshold, the needle gripper sends error message 07 via IO-Link and stops any movement of the needles. The green power-LED also goes out.

In addition to this, a sensor voltage supply which is too high is also detected, error message 17 is then sent via IO-Link and stops any movement of the needles. see. 6.5, Production-setup profile

 <b>WARNING</b>	
	<p><b>Sensor voltage interruption</b></p> <p>Controller “loses” needle position</p> <p>▶ Return the needle to the home position, see section 6.2.1.</p>

### 6.4.12 Energy monitoring (EM)

To optimize the energy efficiency of the gripping systems, the needle gripper provides functions for the measuring energy consumption.

The system continually records the value of voltage and current. The measured values serve as the basis for the various energy monitoring analysis functions.

The measured values from energy monitoring for a gripping cycle are available via IO-Link from the beginning of each subsequent gripping cycle.



The values are determined via comparison tables based on current process parameters. The needle gripper is not a calibrated measuring device, but the value can still be used as a reference and for comparative measurements.

## 6.5 Production setup profiles

The needle gripper can store up to four different production setup profiles (P-0 to P-3). Here the speed and position data are stored. The profiles are selected using the PDO byte 0 process data byte. This gives users a quick, convenient option for adjusting the parameters to different workpiece properties.





In the default setting, the P-0 production setup profile is selected.

# 7 Maintenance and Accessories

## 7.1 General maintenance

! CAUTION	
	<p><b>Maintenance of the gripper under voltage and / or compressed air</b>                      Personal injury and/or damage to property</p> <ul style="list-style-type: none"> <li>▶ Disconnect the gripper completely from the supply lines</li> <li>▶ Secure the machine / plant / system so that it cannot be switched on again</li> </ul>

! CAUTION	
 	<p><b>Hot drive heat sink</b>                      This presents a burn hazard</p> <ul style="list-style-type: none"> <li>▶ Allow the gripper to cool for 15min</li> <li>▶ Wear gloves</li> </ul>

The maintenance intervals are heavily dependent on the operating conditions and must therefore be determined for the respective process. In particular, operation under difficult conditions, such as

- Conditions with high levels of dust or loose particles from workpieces, or
- high levels of needle wear, due to hard or abrasive workpieces, for example,

can make it necessary to considerably shorten the maintenance interval.



### 7.1.1 Exterior dirt



Remove exterior dirt with a soft cloth and soap suds (max. 60°C).

### 7.1.2 Interior dirt



In the event of interior dirt, open the maintenance openings on the gripper module as described in chapter **Fehler! Verweisquelle konnte nicht gefunden werden.**, remove the needle holders and remove the dirt with a compressed-air gun.



! CAUTION	
	<p><b>The needle holder can be forced out by compressed air (blown out)</b>                      Damage to the eyes</p> <ul style="list-style-type: none"> <li>▶ Remove the needle holders before starting the cleaning procedure</li> <li>▶ Wear protective glasses</li> </ul>



! CAUTION	
 	<p><b>Air flow due to blowing out with compressed air</b>                      Damage to eyes</p> <ul style="list-style-type: none"> <li>▶ Do not look into the exhaust air stream</li> <li>▶ Wear protective glasses</li> </ul>

 <b>CAUTION</b>	
 	<p><b>Emission of respirable particles</b>                      Damage to respiratory tract</p> <ul style="list-style-type: none"> <li>▶ Wear respiratory protection</li> </ul>

### 7.1.3 Opening and sealing the maintenance openings

 <b>WARNING</b>	
 	<p><b>Exposed needles</b>                      Injuries caused by pricks, cuts and scratches</p> <ul style="list-style-type: none"> <li>▶ Wear cut resistant gloves</li> </ul>

 <b>CAUTION</b>	
	<p><b>Falling needle holder</b>                      Damage to eyes</p> <ul style="list-style-type: none"> <li>▶ Wear protective glasses</li> </ul>

 <b>CAUTION</b>	
	<p><b>Maintenance of the gripper under voltage and / or compressed air</b>                      Personal injury and/or damage to property</p> <ul style="list-style-type: none"> <li>▶ Disconnect the gripper completely from the supply lines</li> <li>▶ Secure the machine / plant / system so that it cannot be switched on again</li> </ul>

## Unlocking and removing the cover

Press the bolts of the spring-loaded pressure piece out of the holes with a sharp object (e.g. a pen, screwdriver).

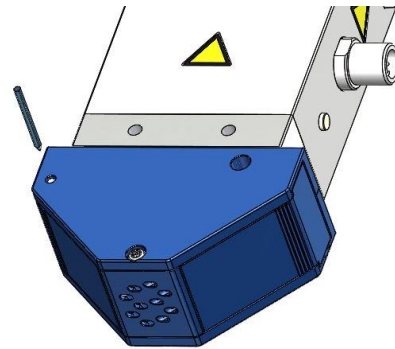

The cover must be pushed out of the housing at the same time as the spring-loaded bolt is actuated. The area (red arrow) is serrated.

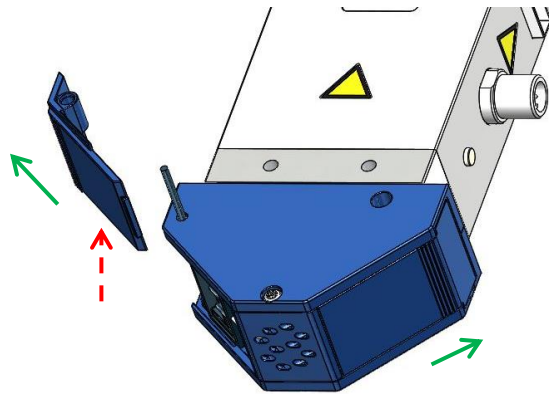

## Removal of the needle holder

Needle holder start position

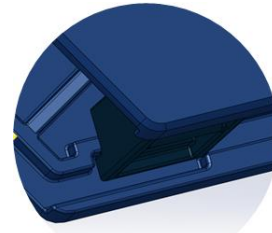

### 1. Removal step

Push the needle holder into the lower position. In doing so, the needle holder is released from engagement with the worm wheel.

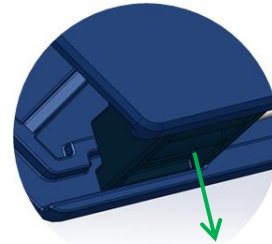

### 2. Removal step

Pull the needle holder out of the housing

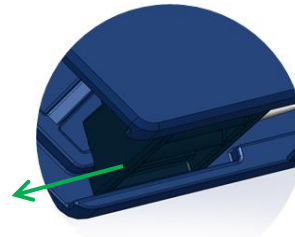

## Inserting the needle holder

Insertion of the needle holder occurs in the same way as removal but in the reverse order. After inserting the needle holders, the needles must always be returned to the home position. See section 6.2.1

### **IMPORTANT**

The position "needle retracted" was adjusted

Malfunctions and damage to the gripper is possible

- ▶ The position "needle retracted" of the gripper must be reached before needle holders can be inserted - see chapter 7.3.
- ▶ No further changes to the position of the worm wheels may be made after the needle holders have been inserted

## Installation of the cover

Installation of the covers occurs in the same way as removal but in the reverse order.



The pressure bolts make an audible click if the covers have been mounted correctly.

### IMPORTANT

#### Operation of the gripper without covers

Malfunctions and damage to the gripper

- ▶ Covers of the needle holder must be ensured

## Inspecting the gripper after the needle holders have been changed

If the aforementioned installation steps were carried out successfully,

- 1.) the needles do not protrude from the grip surface of the housing
- 2.) the two needle holders have the same stroke
- 3.) the needle stroke corresponds to the set stroke in the scale

Should one of the requirements not be met, the following steps are to be performed:

1. Remove the two needle holders. See 7.1.3
2. Start up the position "needle retracted" again
  - 3 Insert the two needle holders. See 7.1.3



We recommend a test run prior to start of operations for the gripper.



## 7.2 Warranty, Spare Parts and Wearing Parts

This system is guaranteed in accordance with our general terms of trade and delivery. The same applies to spare parts, provided that these are original parts supplied by us. We are not liable for any damage resulting from the use of non-original spare parts or accessories.



Opening the gripper's drive unit destroys the "tested" sticker. The factory warranty is then no longer valid.

Wearing parts are not covered by the warranty. The following list contains the primary spare and wearing parts.

### 7.2.1 Spare and Wearing Parts

Type	Designation	Content	Part no.	Legend
SNGi-AE 10 0.8 V 3	Spare parts set	2 Mounting adapters needle	10.01.29.00405	W
SNGi-AE 10 1.2 V 3	Spare parts set	2 Mounting adapters needle	10.01.29.00406	W
SNGi-AE 10 0.8 V 10	Spare parts set	2 Mounting adapters needle	10.01.29.00407	W
SNGi-AE 10 1.2 V 10	Spare parts set	2 Mounting adapters needle	10.01.29.00408	W
SNGi-AE 10 1.2 V 20	Spare parts set	2 Mounting adapters needle	10.01.29.00409	W
SNGi-AE 10 0.8 V 3	Spare parts set	Cover	10.01.29.00419	S
SNGi-AE 10 1.2 V 3	Spare parts set	Cover	10.01.29.00419	S
SNGi-AE 10 0.8 V 10	Spare parts set	Cover	10.01.29.00420	S
SNGi-AE 10 1.2 V 10	Spare parts set	Cover	10.01.29.00420	S
SNGi-AE 10 1.2 V 20	Spare parts set	Cover	10.01.29.00421	S

Legend: Spare part = **S** Wearing part = **W**

## 7.3 Troubleshooting

Fault	Possible Cause	Solution
Needle does not extend	No release	Set the move-enable bit in PD Out byte 0 to 0 and then to 1
	Max. punching force exceeded	Return the needle to the home position
	Insufficient sensor power supply	Check the voltage
	Insufficient actuator power supply	Check the voltage and switch it on, if necessary
	Sensor power supply exceeded	Check the voltage and reduce it, if necessary
	Actuator power supply exceeded	Check the voltage and reduce it, if necessary
	Heavy soiling in the interior of the gripper module	See general maintenance - interior dirt
Workpiece cannot be held	Needle stroke too low	Increase needle stroke
	Needle sags	Select a needle gripper with a greater needle diameter
	Needle is broken	Replace the needle holder
Needle holders have different strokes	The position of the worm wheels was changed between insertion of the first and second needle holder	<ol style="list-style-type: none"> <li>1. Remove the two needle holders. see 7.1.3</li> <li>2. Insert the two needle holders. see 7.1.3</li> <li>3. Return the needle to the home position</li> </ol>
The entire stroke range is no longer available	Heavy soiling in the interior of the gripper module	See general maintenance - interior dirt
The preset stroke is no longer reached after the needle is changed	The position of the worm wheels was changed prior to inserting the needle holders	Return the needle to the home position

## 7.4 Accessories

Designation		Part no.
Holder system	HTS-A2 AP SNG	10.01.29.00402
Holder system	HTS-A3 AP SNG	10.01.29.00322
Fastening plate	BEF-PL 11.5x15x38 G1/4-IG SNG	10.01.29.00403
Connection cable for sensor	ASK-S-M12-5 to B-M12-5 1000	21.04.05.00158
Connection cable for sensor	ASK-S-M12-5 to B-M12-5 2000	21.04.05.00211
Connection cable	ASV IO-LINK B-M12-5 to 2xM12-4	10.02.02.04336
Connection cable for sensor	ASK B-M12-5 5000 PUR GE	21.04.05.00080

A list of IO-Link masters approved by Schmalz can be found under the relevant parts at [www.schmalz.com](http://www.schmalz.com)

## 7.5 Decommissioning

After being exchanged or after final decommissioning, the needle gripper, as well as the components and assemblies that were replaced, are to be disposed of in accordance with country-specific guidelines.

<b>IMPORTANT</b>	
	<p>Incorrect disposal of the gripper Environmental damage</p> <ul style="list-style-type: none"><li>▶ Disposal according to country-specific guidelines</li></ul>

## 8 Explanations of terms

- **Data Dictionary:** The process data and parameters available via O-Link are listed in this separate PDF file.
- **Device Access Locks:** This is an additional parameter which makes it possible to protect the parameter values from unauthorized overwriting.
- **EPC:** Energy and process control
- **EPC-ACK:** EPC-Acknowledge bit; confirmation bit, which confirms that the needle gripper has received the change.
- **ISDU:** Indexed service data unit, acyclically requested parameter data between SPS and IO-Link device

# 9 Conformity Declaration

DE EG-Konformitätserklärung  
 EN EC-Declaration of Conformity  
 FR CE-Déclaration de conformité  
 ES Certificado de conformidad CE  
 IT Dichiarazione di conformità CE  
 NL CE Conformiteitsverklaring



Hersteller / Manufacturer/ Fabricant / Fabricante / Produttore / Fabrikant

J. Schmalz GmbH, Aacher-Str. 29, D - 72293 Glatten

Produktbezeichnung / Product name / Designation du produit /  
 Denominación del producto / Denominazione del prodotto / Beschrijving van de machine

Nadelgreifer der Serie / Needle gripper, Series / Préhenseur à aiguilles de la série /  
 Pinzas de la serie / Pinza di presa ad aghi, serie / Naaldgriper Serie

SNGI-AE

Erfüllte einschlägige EG-Richtlinien / Applicable EC directives met / Directives CE applicables respectées

2006/42/EG	Maschinenrichtlinie / Machinery Directive / Directive sur les machines / Directiva para máquinas / Direttiva macchine / Machinerichtlijn
2004/108/EG	Elektromagnetische Verträglichkeit / Electromagnetic Compatibility / Compatibilité électromagnétique / Compatibilidad electromagnética / Compatibilità elettromagnetica / Elektromagnetische compatibiliteit
2006/95/EG	Niederspannungsrichtlinie / Low Voltage Directive / Directive basse tension / Directiva de baja tensión / Direttiva sulla bassa tensione / Laagspanningsrichtlijn

Angewendete harmonisierte Normen / Harmonised standards applied / Normes d'harmonisation appliquées

EN ISO 12100	Sicherheit von Maschinen - Grundbegriffe, allgemeine Gestaltungsleitsätze - Risikobeurteilung / Safety of Machinery - Basic concepts, general principles for design - Risk assessment / Sécurité des machines - Notions fondamentales, principes généraux de conception - Appréciation du risque / Seguridad de máquinas - Principios generales de diseño - Evaluación del riesgo y reducción del riesgo / Sicurezza delle macchine - Principi generali di progettazione - Valutazione del rischio e riduzione del rischio / Veiligheid van machines - Algemene beginselen voor ontwerp - Risicobeoordeling en de risicoreductie
EN 60204-1	Sicherheit von Maschinen - Elektrische Ausrüstung von Maschinen / Safety of Machinery - Electrical equipment of machines / Sécurité des machines - Équipement électrique des machines / Seguridad de máquinas - Equipamiento eléctrico de máquinas / Sicurezza delle macchine - Equipaggiamento elettrico delle macchine / Veiligheid van machines - elektrische uitrusting van machines
EN 61000-6-2	Elektromagnetische Verträglichkeit - Störfestigkeit / Electromagnetic Compatibility - Immunity / Compatibilité électromagnétique - Immunité / Compatibilidad electromagnética - Resistencia a interferencias / Compatibilità elettromagnetica - Immunità / Elektromagnetische compatibiliteit - immunititeit
EN 61000-6-3	Elektromagnetische Verträglichkeit - Störaussendung / Electromagnetic Compatibility - Emission / Compatibilité électromagnétique - Norme sur l'émission / Compatibilidad electromagnética - Emisión de interferencias / Compatibilità elettromagnetica - Norma generica sull'emissione / Elektromagnetische compatibiliteit - emissie

Dokumentationsverantwortlicher / Person responsible for documentation / Responsable de la documentation / Responsable de documentación /  
 Responsabile della documentazione / Verantwoordelijk voor de documentatie

Glatten, 18.11.2014

  
 Klaus-Dieter Fanta / J. Schmalz GmbH, Aacher-Str. 29, D - 72293 Glatten

Unterschrift, Angaben zum Unterzeichner / Signature, details of signatory / Signature, indications sur le sousigné /  
 Firma y datos del firmante / Firma, dati concernenti il firmatario / Handtekening, omschrijving van de ondertekenaar

Glatten, 18.11.2014

  
 Walter Dunkmann  
 Leiter Geschäftsentwicklung Vakuumkomponenten / Head of Business Development for Vakuum Components

## At your service worldwide



● **Headquarters**  
Hauptsitz

Schmalz Germany – Glatten

● **Sales and production companies**  
Vertriebs- und Produktionsgesellschaften

Schmalz China – Shanghai  
 Schmalz India – Pune  
 Schmalz Japan – Yokohama  
 Schmalz USA – Raleigh (NC)

● **Sales companies**  
Vertriebsgesellschaften

Schmalz Australia – Melbourne  
 Schmalz Benelux – Hengelo (NL)  
 Schmalz Canada – Mississauga  
 Schmalz Finland – Vantaa  
 Schmalz France – Champs-sur-Marne  
 Schmalz Italia – Novara  
 Schmalz Mexiko – Querétaro

Schmalz Poland – Suchy Las (Poznan)  
 Schmalz Russia – Moskow  
 Schmalz South Korea – Anyang  
 Schmalz Spain – Erandio (Vizcaya)  
 Schmalz Switzerland – Nürens Dorf  
 Schmalz Turkey – Istanbul

• **Sales partners**  
Vertriebspartner

You can find the Schmalz sales partner in your country at:  
[WWW.SCHMALZ.COM/SALESNETWORK](http://WWW.SCHMALZ.COM/SALESNETWORK)

Den Schmalz Vetriebspartner in Ihrem Land finden Sie auf:  
[WWW.SCHMALZ.COM/VERTRIEBSNETZ](http://WWW.SCHMALZ.COM/VERTRIEBSNETZ)

**J. Schmalz GmbH**  
 Johannes-Schmalz-Str. 1  
 72293 Glatten, Germany  
 T: +49 7443 2403-0  
 schmalz@schmalz.de  
 WWW.SCHMALZ.COM

30.30.01.00576/03 | 05.2019